

LAYOUT NOTES:

- 1) THE CONTRACTOR SHALL CONTACT LANDSCAPE ARCHITECT TO INSPECT ALL LAYOUT STAKING PRIOR TO CONSTRUCTION.
- 2) THE CONTRACTOR SHALL VERIFY ALL DIMENSIONS ON THE GROUND AND REPORT ANY DISCREPANCIES IMMEDIATELY TO THE LANDSCAPE ARCHITECT.
- 3) THE POINTS OF BEGINNING FOR THE COURTYARD DIMENSIONING ARE THE CORNERS OF THE COURTYARD. DIMENSIONS ARE TO THE OUTSIDES OF THE RAISED PLANTER WALLS AND THE OUTSIDES OF THE DOG PARK MOW STRIPS.
- 4) THE PERGOLAS ARE CUSTOM DESIGNS BY BALDWIN PERGOLAS (baldwinpergolas.com, PHONE # 800-344-5103), CONSTRUCTED OF COLOR-COATED FIBERGLASS & ALUMINUM. THE CONTRACTOR SHALL CONTACT BALDWIN TO OBTAIN SHOP DRAWINGS, WHICH SHALL INCLUDE FOOTING DESIGNS STAMPED BY A MASSACHUSETTS PROFESSIONAL ENGINEER. THE DRAWINGS SHALL BE SUBMITTED TO THE LANDSCAPE ARCHITECT FOR APPROVAL. THE PERGOLA PAINT COLOR SHALL BE SELECTED BY THE LANDSCAPE ARCHITECT OR ARCHITECT (SAME COLOR AS PAVILION COLUMNS). ALSO SEE LIGHTING/OUTLET LAYOUT SHEET FOR LIGHTS & OUTLETS ATTACHED TO PERGOLA BEAMS & COLUMNS.
- 5) FIRE TABLES (4 TOTAL) SHALL BE LINEAR COVE 72", MIDNIGHT MIST COLOR, # CV-72MM, MANUAL IGNITION, BY THE OUTDOOR GREATROOM COMPANY (outdoorrooms.com, PHONE # 866-303-4028). THESE SHALL BE ASSEMBLED ACCORDING TO MANUFACTURER'S INSTRUCTIONS, AND PLACED DIRECTLY ON THE PATIO PAVEMENT.
- 6) SEE DETAIL ON SHEET L-7 FOR GRILL STATION COMPONENTS.
- 7) THE GRILLS AND FIRE PITS SHALL BE SUPPLIED WITH NATURAL GAS. SEE MECHANICAL DRAWINGS FOR GAS SUPPLY.
- 8) THE BENCHES IN THE DOG PARK SHALL BE # 500-60PL BY DUMOR (dumor.com), WITH BLACK POWDER-COATED STEEL FRAME AND RECYCLED PLASTIC SEAT SLATS, GRAY COLOR, SURFACE-MOUNT. BENCHES SHALL BE MOUNTED ON CONCRETE PADS SO THAT FRONT EDGES OF BENCHES ARE 18" FROM FRONT EDGE OF PAD, AND CENTERED IN INDIVIDUAL PADS LENGTH-WISE. REPRESENTATIVE FOR DUMOR IS O'BRIEN & SONS (obrienandsons.com, PHONE # 800-835-0056), MOUNT ACCORDING TO MANUFACTURER'S INSTRUCTIONS, USING RUST-RESISTANT HARDWARE.
- 9) DOG DRINKING FOUNTAIN SHALL BE # 50 SMSS, GREEN COLOR, BY MOST DEPENDABLE FOUNTAINS (mostdependable.com, PHONE # 901-867-0039). INSTALL ACCORDING TO MANUFACTURER'S INSTRUCTIONS, USING RUST-RESISTANT HARDWARE. SEE PLUMBING SHEETS FOR WATER SUPPLY.
- 10) PEDESTAL HOSE BIB IN DOG PARK SHALL BE # MDF 24-8 SMSS W/ RECESSED HOSE BIBB (24" PEDESTAL), GREEN COLOR, BY MOST DEPENDABLE FOUNTAINS (mostdependable.com, PHONE # 901-867-0039). INSTALL ACCORDING TO MANUFACTURER'S INSTRUCTIONS, USING RUST-RESISTANT HARDWARE. SEE PLUMBING SHEETS FOR WATER SUPPLY.
- 11) PET WASTE STATION SHALL BE "RETRIEVER CITY PET WASTE STATION", DEEP GREEN COLOR, BY GLASDON, INC. (us.glasdon.com, PHONE # 855-874-5273). SECURE TO PAVEMENT WITH RUST-RESISTANT HARDWARE, ACCORDING TO MANUFACTURER'S INSTRUCTIONS.

LEGEND

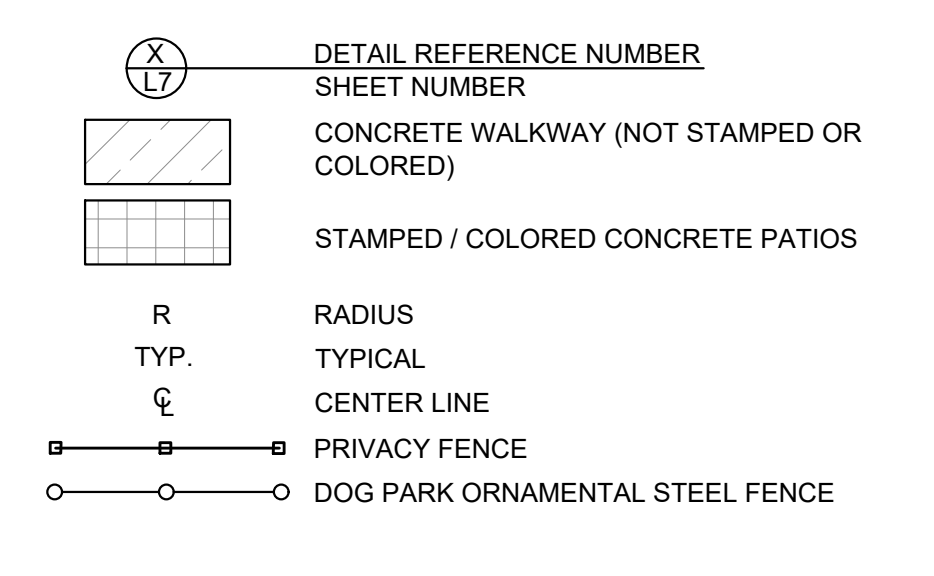

PROJECT:
274 FRANKLIN ST.
WORCESTER, MA

CLIENT:
GOVENTURE
CAPITAL GROUP

DATE: 9-25-23

REVISIONS:

NO.	DATE	DESCRIPTION

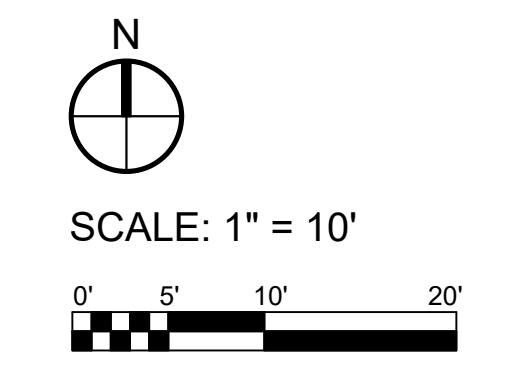

COURTYARD LAYOUT & MATERIALS PLAN

SHEET L-1 OF 10

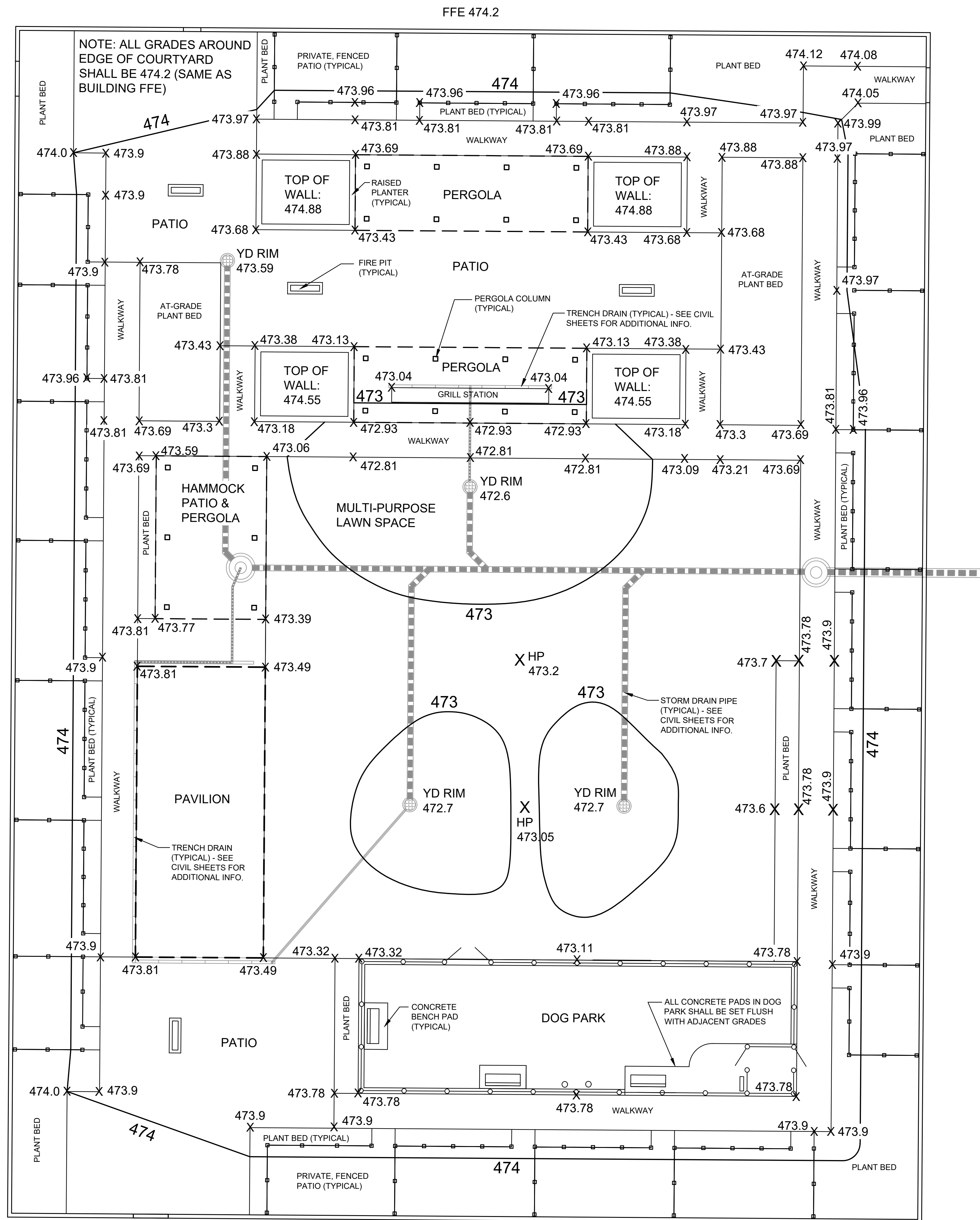

COURTYARD GRADING NOTES:

- 1) THE CONTRACTOR SHALL CONTACT THE LANDSCAPE ARCHITECT TO CHECK ROUGH AND FINAL GRADES.
- 2) THE CONTRACTOR SHALL VERIFY ALL GRADES ON THE GROUND AND REPORT ANY DISCREPANCIES TO THE LANDSCAPE ARCHITECT. IF THE BUILDING FINISHED FLOOR ELEVATION CHANGES FROM 474.2, ALL SPOT GRADES IN THE COURTYARD, INCLUDING DRAIN INLET ELEVATIONS, WILL NEED TO BE ADJUSTED THE SAME AMOUNT.
- 3) SEE CIVIL SHEETS FOR STORM DRAIN SYSTEM INFORMATION.

LEGEND

X 473.43 PROPOSED SPOT GRADE

473 PROPOSED CONTOUR



PROJECT:
274 FRANKLIN ST.
WORCESTER, MA

CLIENT:
GOVENTURE
CAPITAL GROUP

DATE: 9-25-23

REVISIONS:

NO.	DATE	DESCRIPTION

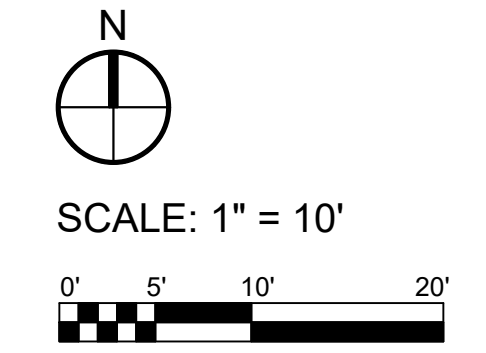

**COURTYARD
GRADING PLAN**

SHEET L-2 OF 10

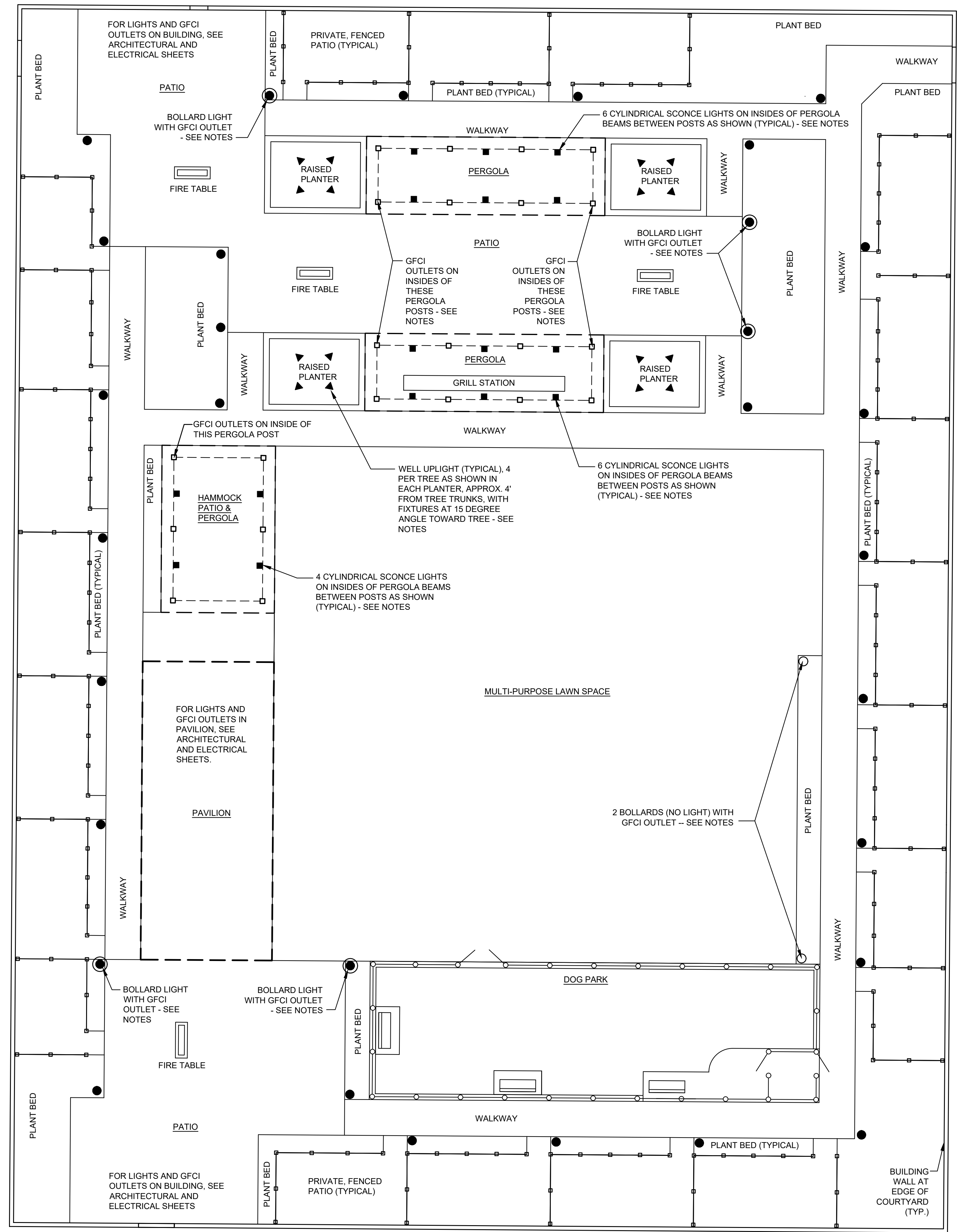

LIGHTING & OUTLET NOTES:

- 1) BOLLARD LIGHTS: 31 TOTAL, INCLUDING 5 WITH BUILT-IN GFCI OUTLETS. THESE LIGHTS SHALL BE FB 600-IBP LED SERIES BY ALUMILITE, MODEL # FB-IBP-630/20W/LED-42IN-30K-BK FOR THOSE WITHOUT GFCI OUTLETS, AND # FB-IBP-630/20W/LED-42IN-30K-BK-GFCI FOR THOSE WITH OUTLETS. BOLLARD LIGHTS SHALL HAVE THE FOLLOWING CUSTOMIZATION: NO ORNATE BASE (VERTICAL BOLLARD ONLY) AND 14" LENS ASSEMBLY. BOLLARDS SHALL BE BLACK COLOR, AND FIXTURE SHALL BE 3000 KELVIN. LOCAL REP. FOR ALUMILITE IS SK & ASSOCIATES (skandassociates.com, PHONE # 781-232-5366).
- 2) BOLLARDS (NO LIGHT) WITH BUILT-IN GFCI OUTLET: 2 TOTAL. THESE BOLLARDS SHALL BE MANUFACTURED BY ALUMILITE, AND SHALL MATCH DIAMETER, HEIGHT, COLOR, & MATERIAL OF BOLLARDS WITH LIGHTS. MODEL NUMBER IS # FB-IBP-LLS-MDS-42IN-BK-GFCI. LOCAL REP. FOR ALUMILITE IS SK & ASSOCIATES (skandassociates.com, PHONE # 781-232-5366).
- 3) WELL UPLIGHTS: 16 TOTAL, 4 PER RAISED PLANTER. THESE LIGHTS SHALL BE EVOCA EV7 BY LUMASCAPE, # LS793LED-9-H6-MF-N-13-W. LOCAL REP. FOR LUMASCAPE IS SK & ASSOCIATES (skandassociates.com, PHONE # 781-232-5366).
- 4) CYLINDRICAL SCENCE LIGHTS (ON INSIDES OF PERGOLA BEAMS): 16 TOTAL. THESE SHALL BE SUPPLIED BY BALDWIN PERGOLAS, (BLACK COLOR). SEE LAYOUT & MATERIALS SHEET FOR BALDWIN PERGOLAS CONTACT INFORMATION.
- 5) GFCI OUTLETS ON INSIDES OF PERGOLA POSTS: 5 TOTAL. THESE SHALL BE SUPPLIED BY BALDWIN PERGOLAS (MOUNTED AT MINIMUM HEIGHT REQUIRED BY CODE).
- 6) LIGHT FIXTURES SHALL BE INSTALLED IN ACCORDANCE WITH MANUFACTURER'S INSTRUCTIONS. TRANSFORMERS AND ENCLOSURES SHALL BE PROVIDED BY SAME MANUFACTURER AS LIGHTS.
- 7) SEE ELECTRICAL SHEETS FOR POWER SUPPLY INFORMATION.

LEGEND

- BOLLARD LIGHTS (WITHOUT OUTLETS)
- BOLLARD LIGHTS WITH GFCI OUTLETS
- BOLLARDS WITHOUT LIGHTS BUT WITH GFCI OUTLETS
- ▲ WELL UPLIGHTS IN RAISED PLANTERS
- SCENCES ON INSIDES OF PERGOLA BEAMS



PROJECT:
274 FRANKLIN ST.
WORCESTER, MA

CLIENT:
GOVENTURE
CAPITAL GROUP

DATE: 9-25-23

REVISIONS:

NO.	DATE	DESCRIPTION

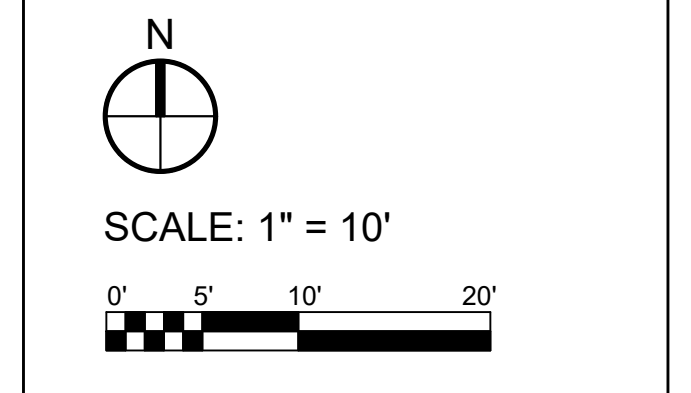

DR 21994, PG 3/10
 MAP 4/1/00014
 (271 FRANKLIN ST)

FRANKLIN STREET PUBLIC 35' WIDE

LAND N/F
 CITY OF WORCESTER
 FIRE DEPARTMENT
 BK 35212, PG 123
 MAP 4/15/0002A
 (266 FRANKLIN ST)

ARCTIC STREET - 50FT WIDE

PLASTICS STREET PRIVATE - 40' WIDE

- NOTES:**
- 1) SEE SHEET L-6 FOR PLANT SCHEDULE AND DETAILS, AND SHEET L-10 FOR TECHNICAL NOTES.
 - 2) PLANT SPECIES, CULTIVARS, SIZES, AND LOCATIONS SHALL NOT BE CHANGED EXCEPT BY PERMISSION OF THE LANDSCAPE ARCHITECT. THE CONTRACTOR SHALL CHECK PLANT MATERIAL FROM NURSERIES BEFORE ACCEPTING PLANTS, TO MAKE SURE THERE ARE NO UNAUTHORIZED SUBSTITUTIONS. ALTERNATE CULTIVARS OF THE SAME SPECIES SHALL NOT BE SUBSTITUTED WITHOUT LANDSCAPE ARCHITECT'S APPROVAL.
 - 3) THE CONTRACTOR SHALL CHECK WITH ALL WHOLESALE NURSERIES WITHIN 100 MILE RADIUS OF THE PROJECT SITE FOR AVAILABILITY OF SPECIFIED PLANT MATERIALS, BEFORE PROPOSING ANY SUBSTITUTES.
 - 4) PLANTS SHALL BE INSTALLED AT LEAST HALF OF THEIR ON-CENTER SPACING FROM ADJACENT WALLS AND PAVEMENT, UNLESS SHOWN OTHERWISE.
 - 5) THE CONTRACTOR SHALL CONTACT THE LANDSCAPE ARCHITECT TO INSPECT THE LAYOUT OF ALL PLANTS ON SITE PRIOR TO INSTALLATION.
 - 6) ALL AREAS TO RECEIVE SEED AND PLANTINGS SHALL FIRST RECEIVE LOAM AS SPECIFIED.
 - 7) ALL NON-PAVED, DISTURBED AREAS OUTSIDE OF PLANTING BEDS SHALL BE SOWN WITH LAWN SEED, AS SPECIFIED.
 - 8) ALL PLANTS IN THIS PROJECT ARE RESISTANT TO ASIAN LONG-HORNED BEETLE INFESTATION.

LEGEND: NOTE: NOT ALL SYMBOLS USED ARE INCLUDED IN THIS LEGEND. (THESE ARE JUST EXAMPLES.)

- PROPOSED GROUNDCOVERS & PERENNIALS
- PROPOSED SHRUBS
- PROPOSED SMALL ORNAMENTAL TREES
- PROPOSED SHADE TREES
- DETAIL REFERENCE NUMBER SHEET NUMBER

earthdesign
 LANDSCAPE ARCHITECTURE
 280 BEVERLY ROAD • WORCESTER, MA 01605
 508-852-2644 • info@edlandarch.com



PROJECT:
 274 FRANKLIN ST.
 WORCESTER, MA

CLIENT:
 GOVENTURE
 CAPITAL GROUP

DATE: 9-25-23

REVISIONS:

NO.	DATE	DESCRIPTION
1	12-2-24	PLANTING REV. DUE TO PARKING REVISIONS

N

SCALE: 1" = 20'

PLANTING PLAN:
 NORTH

SHEET L-4 OF 10

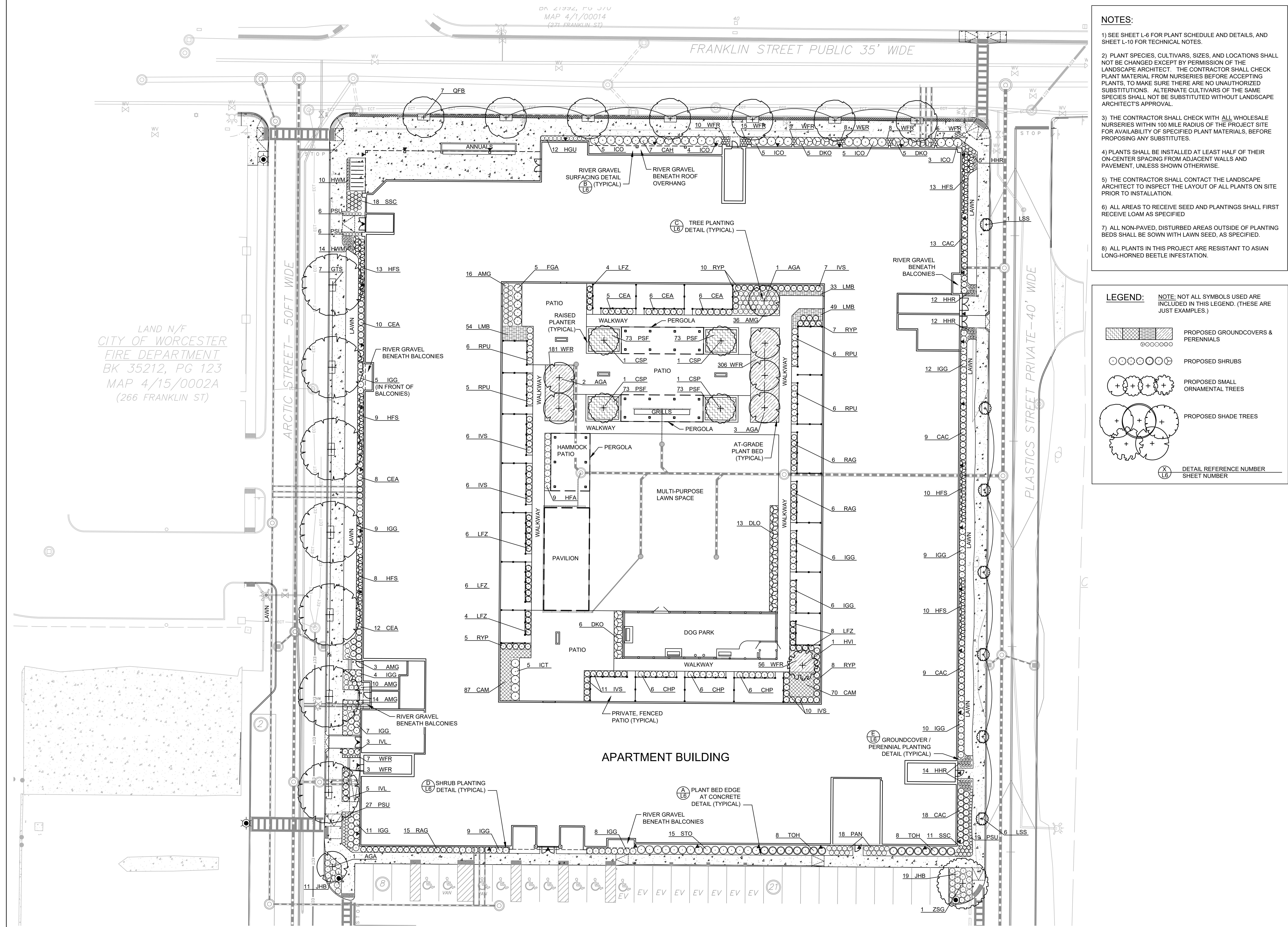



PROJECT:
 274 FRANKLIN ST.
 WORCESTER, MA

CLIENT:
 GOVENTURE
 CAPITAL GROUP

DATE: 9-25-23

REVISIONS:

NO.	DATE	DESCRIPTION
1	12-2-24	PLANTING REV. DUE TO PARKING REVISIONS

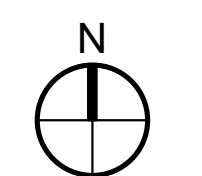

SCALE: 1" = 20'

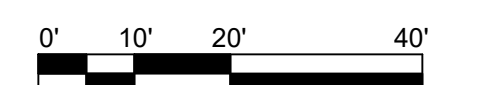

PLANTING PLAN:
 SOUTH

SHEET L-5 OF 10

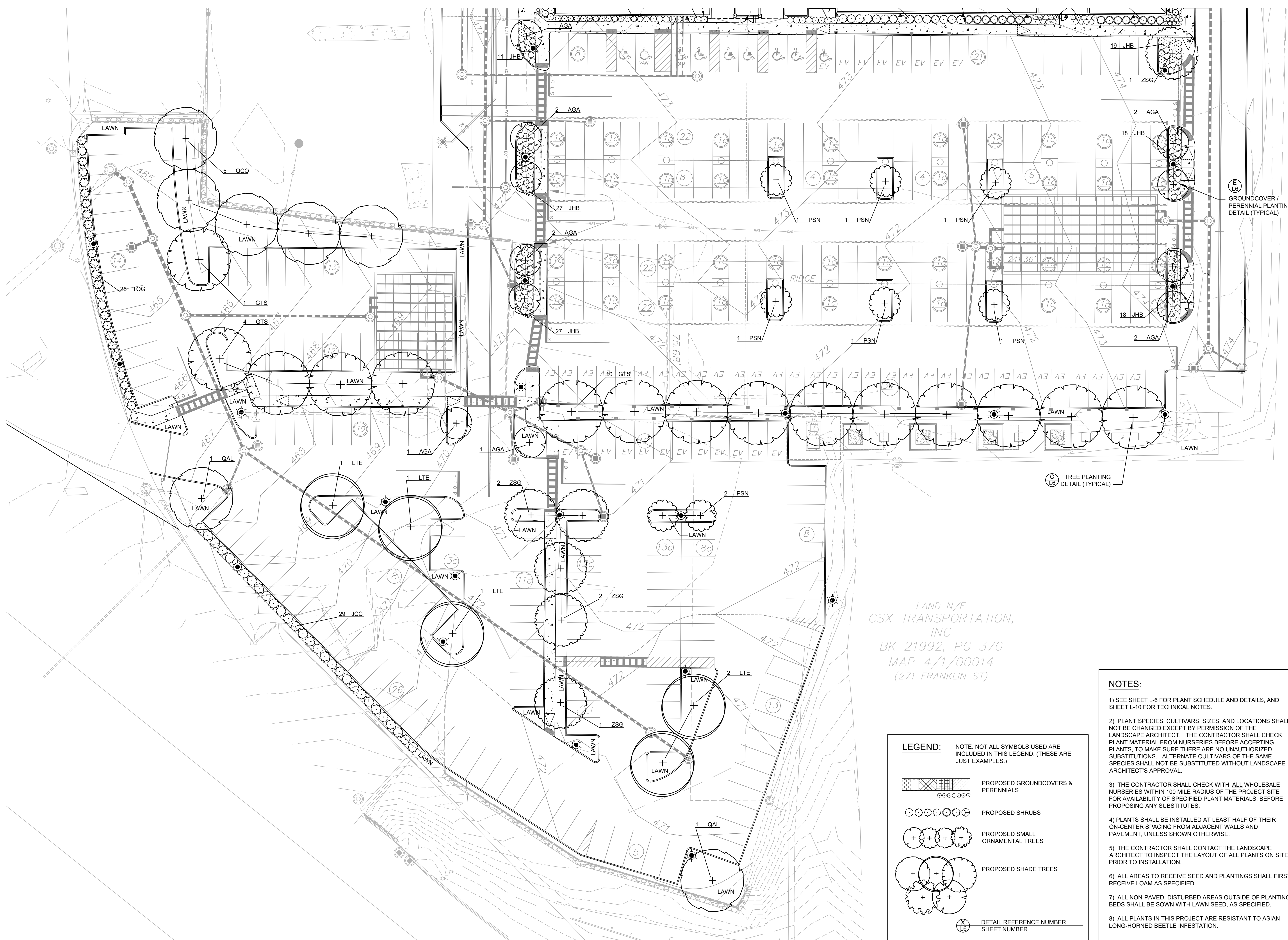

LAND N/F
 CSX TRANSPORTATION,
 INC
 BK 21992, PG 370
 MAP 4/1/00014
 (271 FRANKLIN ST)

LEGEND: NOTE: NOT ALL SYMBOLS USED ARE INCLUDED IN THIS LEGEND. (THESE ARE JUST EXAMPLES.)

- PROPOSED GROUNDCOVERS & PERENNIALS
- PROPOSED SHRUBS
- PROPOSED SMALL ORNAMENTAL TREES
- PROPOSED SHADE TREES
- DETAIL REFERENCE NUMBER SHEET NUMBER

- NOTES:**
- SEE SHEET L-6 FOR PLANT SCHEDULE AND DETAILS, AND SHEET L-10 FOR TECHNICAL NOTES.
 - PLANT SPECIES, CULTIVARS, SIZES, AND LOCATIONS SHALL NOT BE CHANGED EXCEPT BY PERMISSION OF THE LANDSCAPE ARCHITECT. THE CONTRACTOR SHALL CHECK PLANT MATERIAL FROM NURSERIES BEFORE ACCEPTING PLANTS. TO MAKE SURE THERE ARE NO UNAUTHORIZED SUBSTITUTIONS. ALTERNATE CULTIVARS OF THE SAME SPECIES SHALL NOT BE SUBSTITUTED WITHOUT LANDSCAPE ARCHITECT'S APPROVAL.
 - THE CONTRACTOR SHALL CHECK WITH ALL WHOLESALE NURSERIES WITHIN 100 MILE RADIUS OF THE PROJECT SITE FOR AVAILABILITY OF SPECIFIED PLANT MATERIALS, BEFORE PROPOSING ANY SUBSTITUTES.
 - PLANTS SHALL BE INSTALLED AT LEAST HALF OF THEIR ON-CENTER SPACING FROM ADJACENT WALLS AND PAVEMENT, UNLESS SHOWN OTHERWISE.
 - THE CONTRACTOR SHALL CONTACT THE LANDSCAPE ARCHITECT TO INSPECT THE LAYOUT OF ALL PLANTS ON SITE PRIOR TO INSTALLATION.
 - ALL AREAS TO RECEIVE SEED AND PLANTINGS SHALL FIRST RECEIVE LOAM AS SPECIFIED
 - ALL NON-PAVED, DISTURBED AREAS OUTSIDE OF PLANTING BEDS SHALL BE SOWN WITH LAWN SEED, AS SPECIFIED.
 - ALL PLANTS IN THIS PROJECT ARE RESISTANT TO ASIAN LONG-HORNED BEETLE INFESTATION.

NOTE: PLANT SPECIES, CULTIVARS, SIZES, AND LOCATIONS SHALL NOT BE CHANGED EXCEPT BY PERMISSION OF THE LANDSCAPE ARCHITECT. THE CONTRACTOR SHALL CHECK PLANT MATERIAL FROM NURSERIES BEFORE ACCEPTING PLANTS, TO MAKE SURE THERE ARE NO UNAUTHORIZED SUBSTITUTIONS. ALTERNATE CULTIVARS OF THE SAME SPECIES SHALL NOT BE SUBSTITUTED WITHOUT LANDSCAPE ARCHITECT'S APPROVAL.

PLANT SCHEDULE

SYMBOL	QTY.	BOTANICAL NAME	COMMON NAME	MINIMUM SIZE AT PLANTING	PLANT SPACING & NOTES
SHADE TREES:					
GTS	22	GLEDITZIA TRIACANTHOS VAR. INERMIS 'SKYLINE'	SKYLINE HONEYLOCUST	3 - 3.5" CALIPER	B&B, PLANT 30' ON CENTER IN PARKING LOT AND APPROX. 40' ON CENTER ALONG SIDEWALK
LSS	7	LIQUIDAMBAR STYRACIFLUA 'SLENDER SILHOUETTE'	SLENDER SILHOUETTE SWEETGUM	3 - 3.5" CALIPER	B&B, PLANT APPROX. 40' ON CENTER (ALONG SIDEWALK)
LTE	5	LIRIODENDRON TULIPIFERA 'EMERALD CITY'	EMERALD CITY TULIP POPLAR	3 - 3.5" CALIPER	B&B, PLANT 30' ON CENTER WHEN IN GROUPS
QAL	2	QUERCUS ALBA	WHITE OAK	3 - 3.5" CALIPER	B&B, PLANT WHERE SHOWN
QFB	7	QUERCUS ROBUR 'FASTIGIATA' X BICOLOR 'LONG'	REGAL PRINCE ENGLISH OAK	3 - 3.5" CALIPER	B&B, PLANT APPROX. 40' ON CENTER (ALONG SIDEWALK)
QCO	5	QUERCUS COCCINEA	SCARLET OAK	3 - 3.5" CALIPER	B&B, PLANT 30' ON CENTER WHEN IN GROUPS
ZSG	6	ZELKOVA SERRATA 'GREEN VASE'	GREEN VASE ZELKOVA	3 - 3.5" CALIPER	B&B, PLANT 25' ON CENTER WHEN IN GROUPS
SMALL ORNAMENTAL TREES:					
AGA	17	AMELANCHIER X GRANDIFLORA 'AUTUMN BRILLIANCE'	AUTUMN BRILLIANCE SERVICEBERRY	7 - 8' HEIGHT	B&B, MULTI-STEM, PLANT 19' ON CENTER IN PARKING LOT, & 15' ON CENTER IN COURTYARD BEDS
CSP	4	CORNUS X 'STELLAR PINK'	STELLAR PINK DOGWOOD	7 - 8' HEIGHT	B&B, PLANT IN CENTER OF PLANTERS
HVI	1	HAMAMELIS VIRGINIANA	COMMON WITCHHAZEL	7 - 8' HEIGHT	B&B, PLANT WHERE SHOWN
PSN	8	PRUNUS X 'SNOW GOOSE'	SNOW GOOSE CHERRY	7 - 8' HEIGHT	B&B, PLANT WHERE SHOWN
SHRUBS:					
CAC	49	CLETHRA ALNIFOLIA 'CRYSTALINA'	CRYSTALINA SUMMERSWEET	# 3 POT	PLANT 3' ON CENTER
CAH	7	CLETHRA ALNIFOLIA 'HUMMINGBIRD'	HUMMINGBIRD SUMMERSWEET	# 5 POT	PLANT 4' ON CENTER
CEA	47	CEANOTHUS AMERICANUS	NEW JERSEY TEA	# 3 POT	PLANT 3' ON CENTER
CHP	18	CEPHALOTAXUS HARRINGTONIA 'PROSTRATA'	PROSTRATE JAPANESE PLUM YEW	# 3 POT	PLANT 3' ON CENTER
DKO	16	DIERVILLA X 'KODIAK ORANGE'	KODIAK ORANGE BUSH HONEYSUCKLE	# 5 POT	PLANT 4' ON CENTER NORTH OF BUILDING, AND 3'-10" ON CENTER IN COURTYARD.
DLO	13	DIERVILLA LONICERA	NORTHERN BUSH HONEYSUCKLE	# 5 POT	PLANT 4' ON CENTER
FGA	5	FOTHERGILLA GARDENII	DWARF FOTHERGILLA	# 5 POT	PLANT 4' ON CENTER
HFS	63	HYPERICUM FRONDOSUM 'SUNBURST'	SUNBURST ST. JOHN'S WORT	# 3 POT	PLANT 3' ON CENTER. IF UNAVAILABLE, HYPERICUM KALMIANUM 'DEPPE' MAY BE SUBSTITUTED.
ICO	22	ILEX CRENATA 'SOFT TOUCH'	SOFT TOUCH HOLLY	# 3 POT	PLANT 4' ON CENTER
ICT	5	ILEX CRENATA 'STEEDS'	STEEDS HOLLY	# 5 POT	PLANT 4' ON CENTER
IGE	96	ILEX GLABRA 'GEM BOX'	GEM BOX INKBERRY	# 3 POT	PLANT 3' ON CENTER
IVL	8	ITEA VIRGINICA 'LITTLE HENRY'	LITTLE HENRY SWEETSPIRE	# 3 POT	PLANT 3' ON CENTER
IVS	40	ITEA VIRGINICA 'SCENTLANDIA'	SCENTLANDIA SWEETSPIRE	# 3 POT	PLANT 3' ON CENTER
JCC	29	JUNIPERUS CHINENSIS 'HETZI COLUMNARIS'	GREEN COLUMNAR CHINESE JUNIPER	7 - 8' HEIGHT	PLANT 5' ON CENTER
LFZ	28	LEUCOTHOE FONTANESIANA 'ZEBLID'	SCARLETTA DROOPING LAUREL	# 3 POT	PLANT 3' ON CENTER
RAG	27	RHUS AROMATICA 'GRO-LOW'	GRO-LOW SUMAC	# 3 POT	PLANT 3' ON CENTER
RPU	23	RHODODENDRON 'PURPLE GEM'	PURPLE GEM RHODODENDRON	# 3 POT	PLANT 3' ON CENTER
RYP	30	RHODODENDRON YAKUSHIMANUM 'PERCY WISEMAN'	PERCY WISEMAN RHODODENDRON	# 3 POT	PLANT 3' ON CENTER
STO	15	SPIRAEA TOMENTOSA	STEEPLEBUSH	# 5 POT	PLANT 4' ON CENTER
TOG	25	THUJA OCCIDENTALIS 'EMERALD GREEN'	EMERALD GREEN ARBORVITAE	7 - 8' HEIGHT	PLANT 5' ON CENTER
TOH	16	THUJA OCCIDENTALIS 'HETZ MIDGET'	HETZ MIDGET ARBORVITAE	# 5 POT	PLANT 4' ON CENTER
GROUNDCOVERS, PERENNIALS, & ORNAMENTAL GRASSES					
AMG	79	ARONIA MELANOCARPA 'GROUND HUG'	GROUND HUG CHOKEBERRY	# 3 POT	PLANT 2.5' ON CENTER
CAM	157	CAREX AMPHIBOLA	CREEK SEDGE	# 1 POT	PLANT 18" ON CENTER. IF UNAVAILABLE, CAREX MORROWII 'ICE DANCE' MAY BE SUBSTITUTED.
HFA	9	HOSTA 'FRANCEE'	FRANCEE HOSTA	# 1 POT	PLANT 3' ON CENTER
HGU	12	HOSTA 'GUACAMOLE'	GUACAMOLE HOSTA	# 1 POT	PLANT 2' ON CENTER
HHR	43	HEMEROCALLIS X 'HAPPY RETURNS'	HAPPY RETURNS DAYLILY	# 1 POT	PLANT 18" ON CENTER
HWM	24	HEMEROCALLIS X 'WHEN MY SWEETHEART RETURNS'	WHEN MY SWEETHEART RETURNS DAYLILY	# 1 POT	PLANT 18" ON CENTER
JHB	120	JUNIPERUS HORIZONTALIS 'BAR HARBOR'	BAR HARBOR JUNIPER	# 3 POT	PLANT 3' ON CENTER
LMB	136	LIRIOPE MUSCARI 'BIG BLUE'	BIG BLUE LILYTURF	4-INCH POT	PLANT 15" ON CENTER
PAN	18	PANICUM VIRGATUM 'SHENANDOAH'	SHENANDOAH SWITCHGRASS	# 2 POT	PLANT 2.5' ON CENTER
PSF	292	PHLOX SUBULATA 'FORT HILL'	FORT HILL MOSS PHLOX	# 1 POT	PLANT 18" ON CENTER
PSU	58	PHLOX SUBULATA 'PURPLE BEAUTY'	PURPLE BEAUTY MOSS PHLOX	# 1 POT	PLANT 18" ON CENTER
SSC	36	SCHIZACHYRIUM SCOPARIUM	LITTLE BLUESTEM	# 2 POT	PLANT 2' ON CENTER
WFR	604	WALDSTEINIA (GEUM) FRAGARIOIDES	BARREN STRAWBERRY	4-INCH POT	PLANT 18" ON CENTER IN COURTYARD, AND 15" ON CENTER EVERYWHERE ELSE. IF UNAVAILABLE, WALDSTEINIA (GEUM) TERNATA MAY BE SUBSTITUTED.

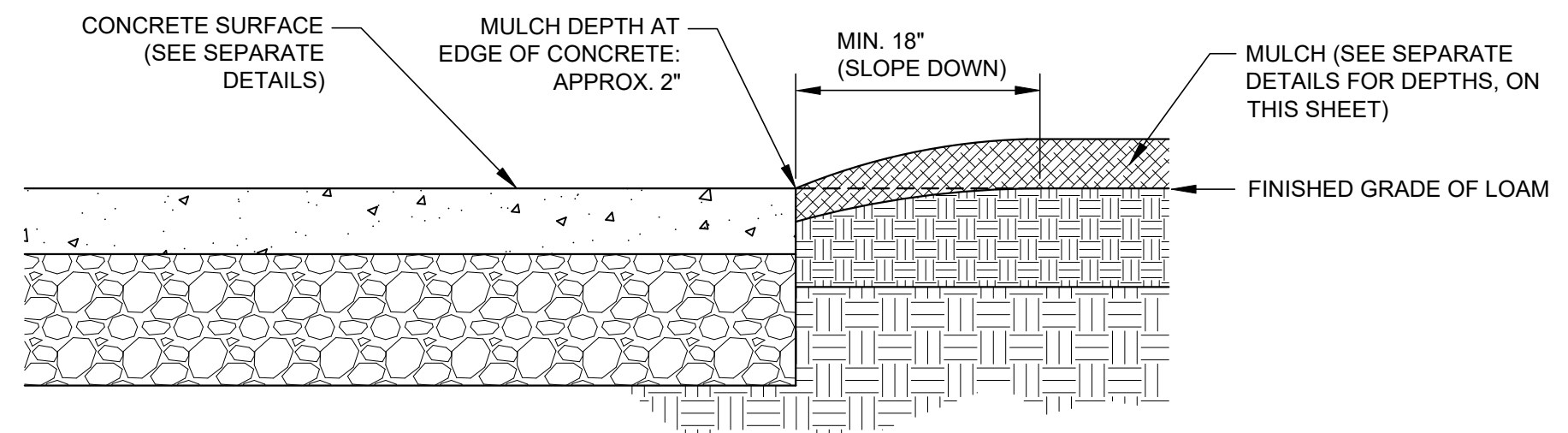

A PLANT BED EDGE AT CONCRETE
L6 SECTIONS NOT TO SCALE

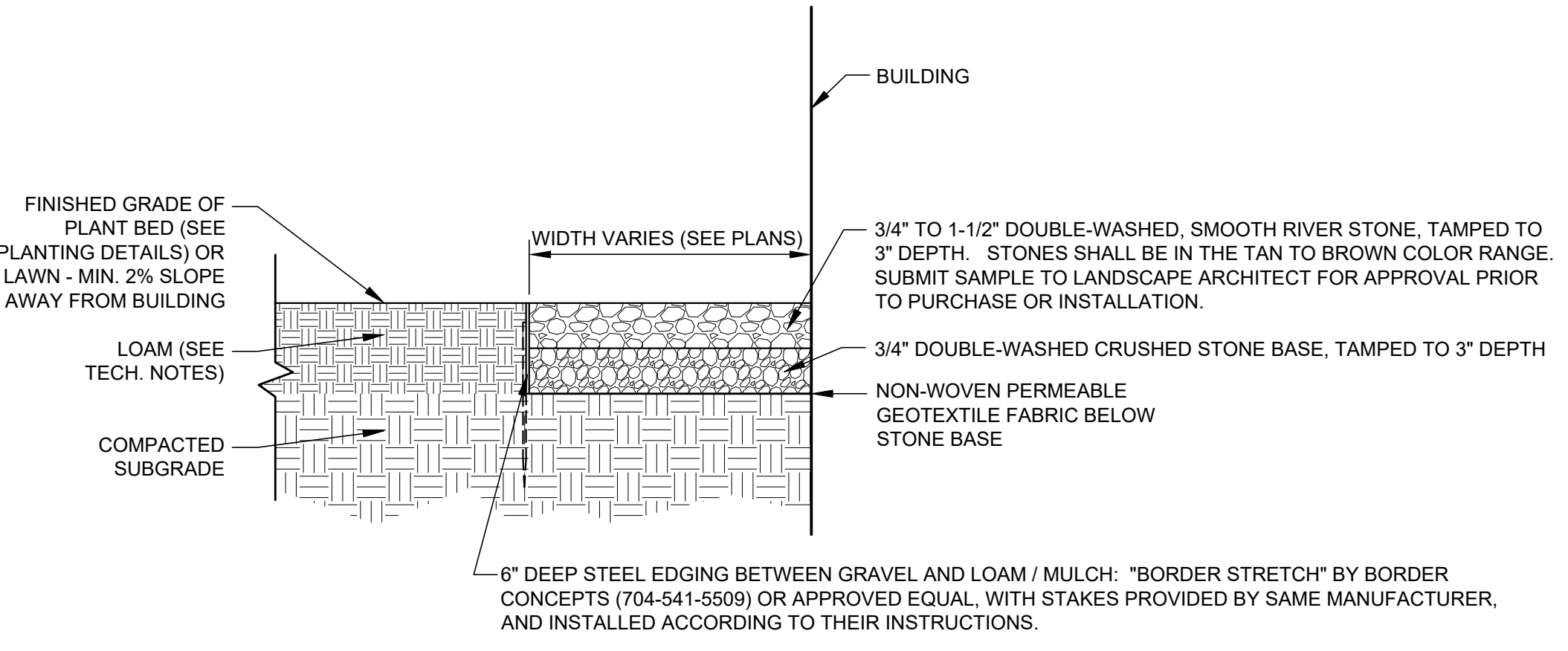

B RIVER GRAVEL SURFACING (BENEATH OVERHANGS)
L6 SECTIONS NOT TO SCALE

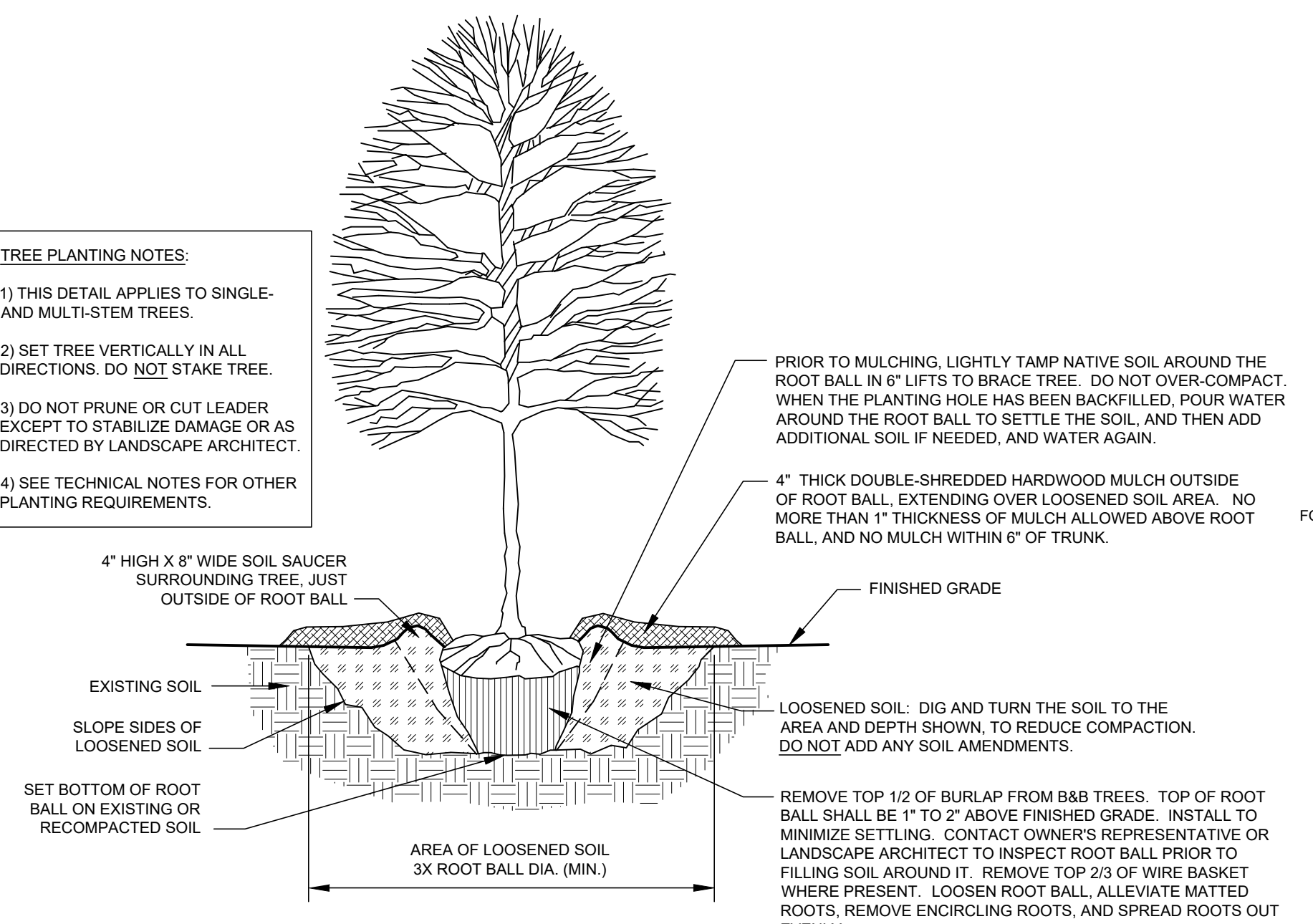

C TREE PLANTING
L6 NOT TO SCALE

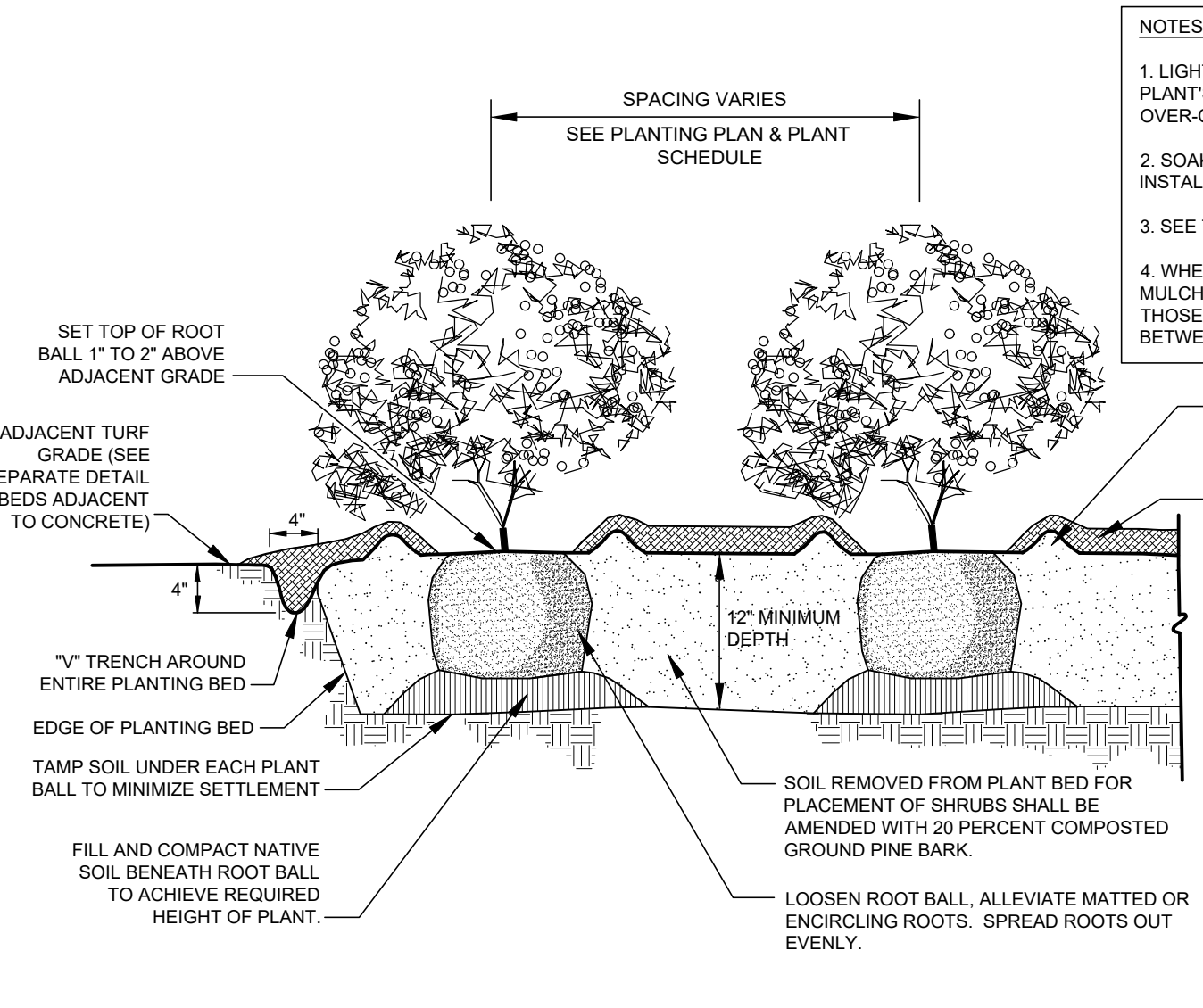

D SHRUB PLANTING
L6 NOT TO SCALE

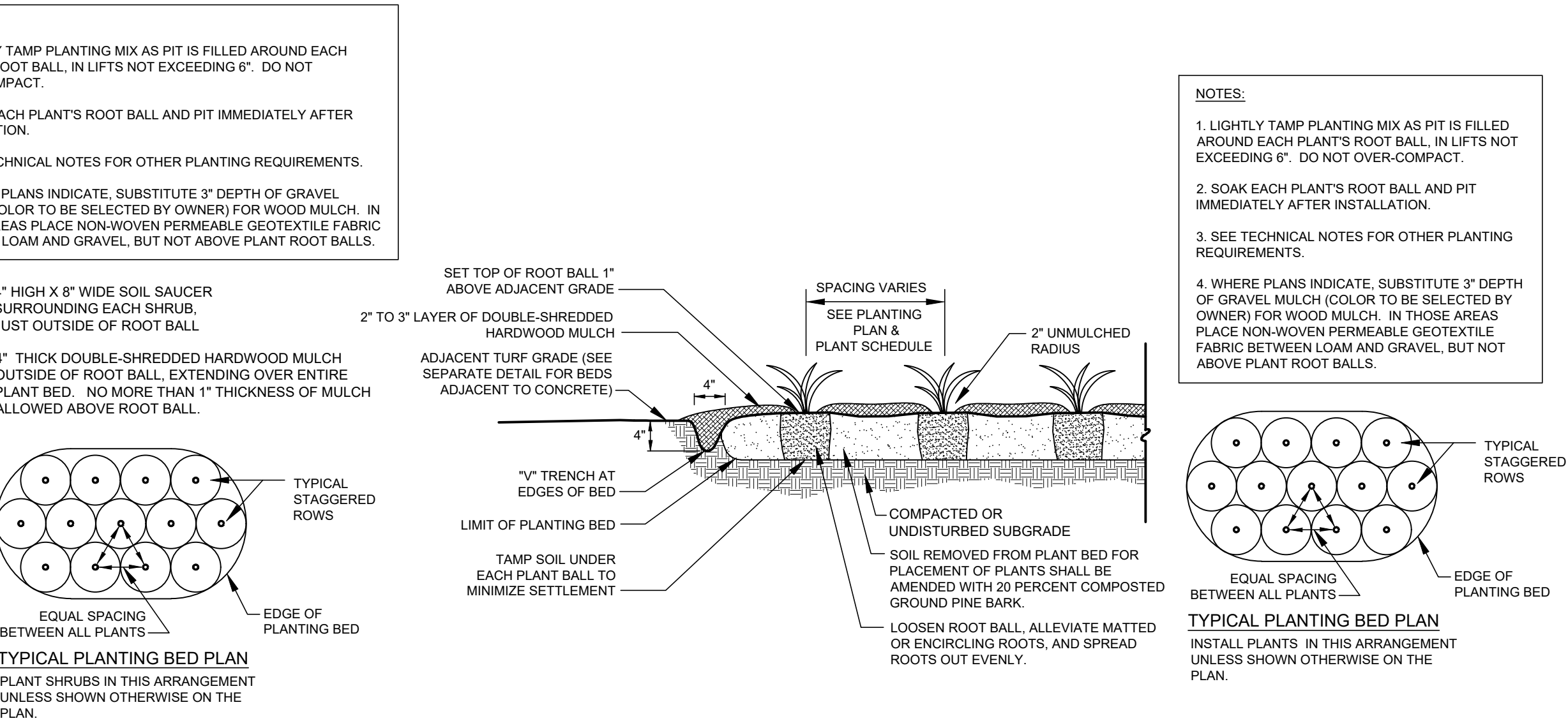

E GROUNDCOVER & PERENNIAL PLANTING
L6 NOT TO SCALE



PROJECT:
274 FRANKLIN ST.
WORCESTER, MA

CLIENT:
GOVENTURE
CAPITAL GROUP

DATE: 9-25-23

REVISIONS:

NO.	DATE	DESCRIPTION
1	12-2-24	PLANTING REV. DUE TO PARKING REVISIONS

SCALE: NONE

PLANT SCHEDULE & DETAILS

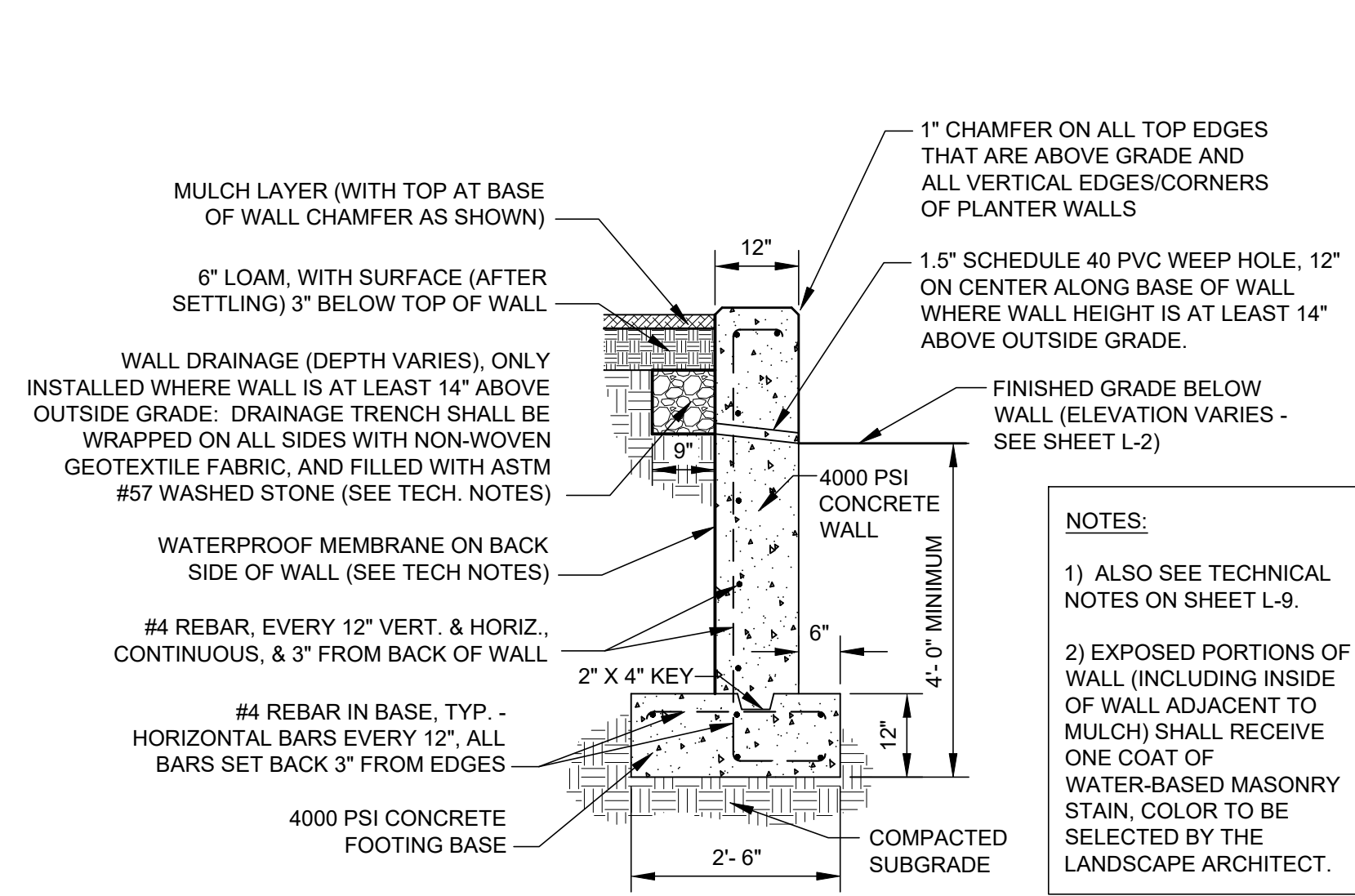

NOTES:
1) ALSO SEE TECHNICAL NOTES ON SHEET L-9.
2) EXPOSED PORTIONS OF WALL (INCLUDING INSIDE OF WALL ADJACENT TO MULCH) SHALL RECEIVE ONE COAT OF WATER-BASED MASONRY STAIN, COLOR TO BE SELECTED BY THE LANDSCAPE ARCHITECT.

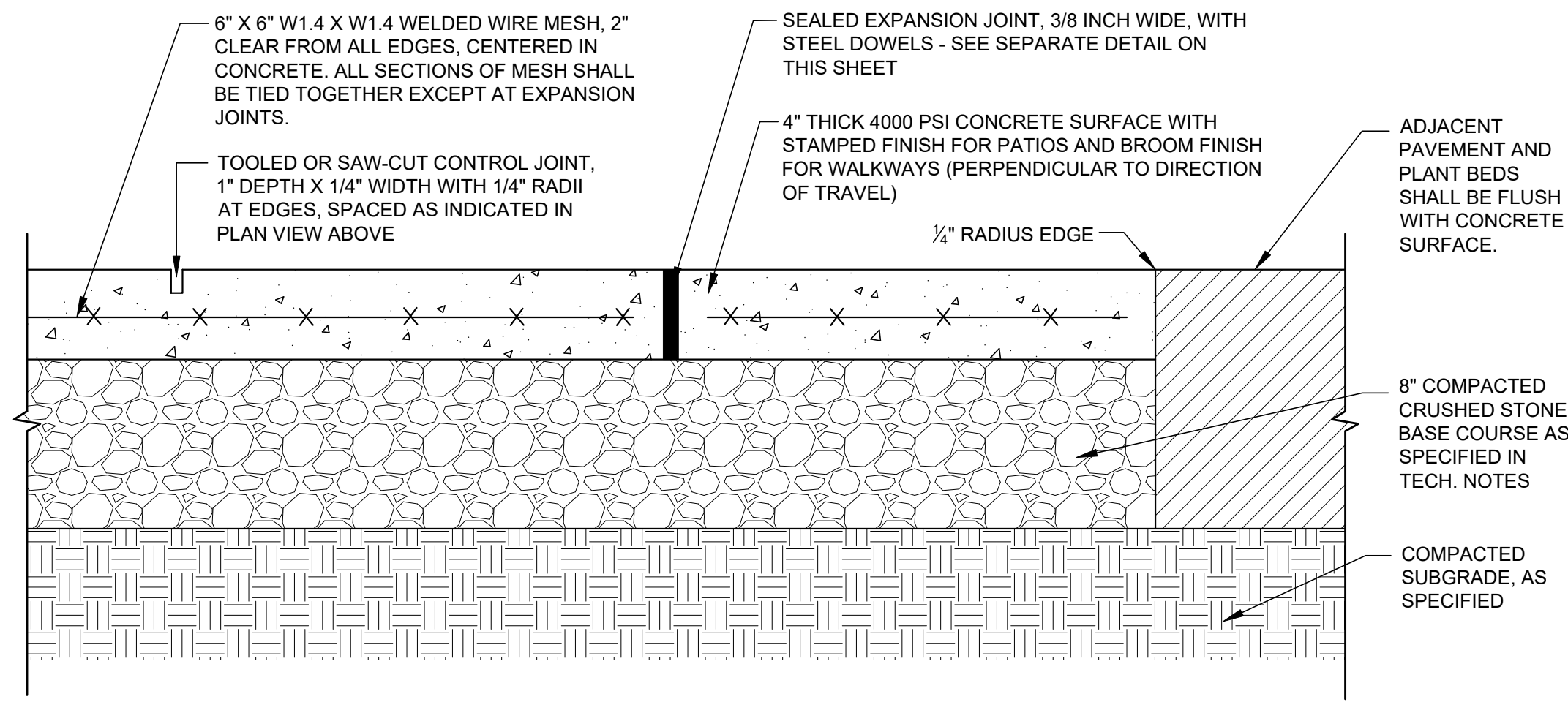

NOTES:
1) CONTROL JOINTS SHALL BE SPACED FROM 6' TO 8' ALONG WALKWAYS (BUT GENERALLY EQUAL), AND A MAXIMUM OF 12' SQUARE IN THE PATIOS.
2) EXPANSION JOINTS SHALL BE SPACED A MAXIMUM OF 30' ALONG THE WALKWAYS, AND MAX. 30' SQUARE IN THE PATIOS. EXPANSION JOINTS IN PRIVATE PATIOS SHALL BE BENEATH & ALIGNED WITH FENCES THAT SEPARATE THE PATIOS. EXPANSION JOINTS SHALL ALSO BE INSTALLED WHERE CONCRETE ABUTS VERTICAL SURFACES AND BETWEEN WALKWAYS AND COMMUNITY (NON-PRIVATE) PATIOS.
3) SEE TECHNICAL NOTES FOR CONCRETE REQUIREMENTS.
4) ALL PATIOS (NOT INCLUDING WALKWAYS) & PAVILION SURFACE SHALL BE STAMPED, COLORED CONCRETE -- SEE PLAN VIEW, THIS DETAIL, AND LAYOUT/MATERIALS PLAN.

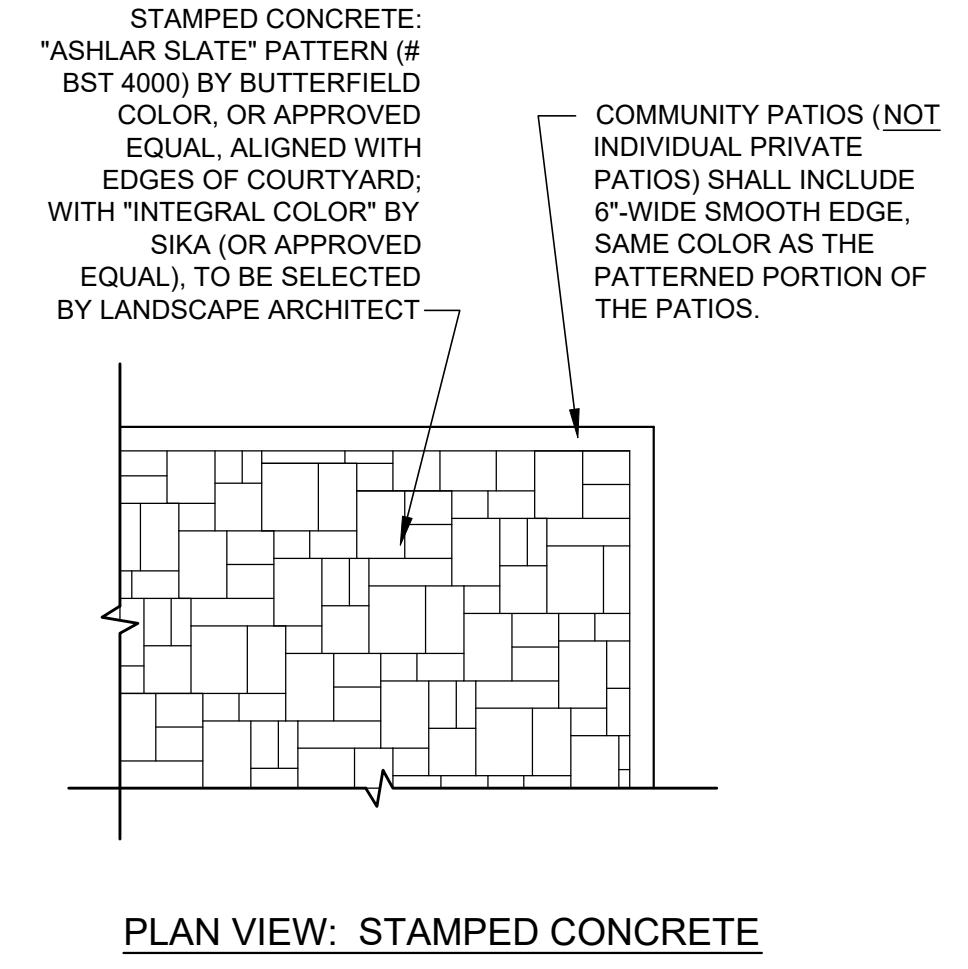

A POURED-IN-PLACE CONCRETE PLANTER WALL
SECTION NOT TO SCALE

B PORTLAND CEMENT CONCRETE PAVEMENT
SECTION NOT TO SCALE

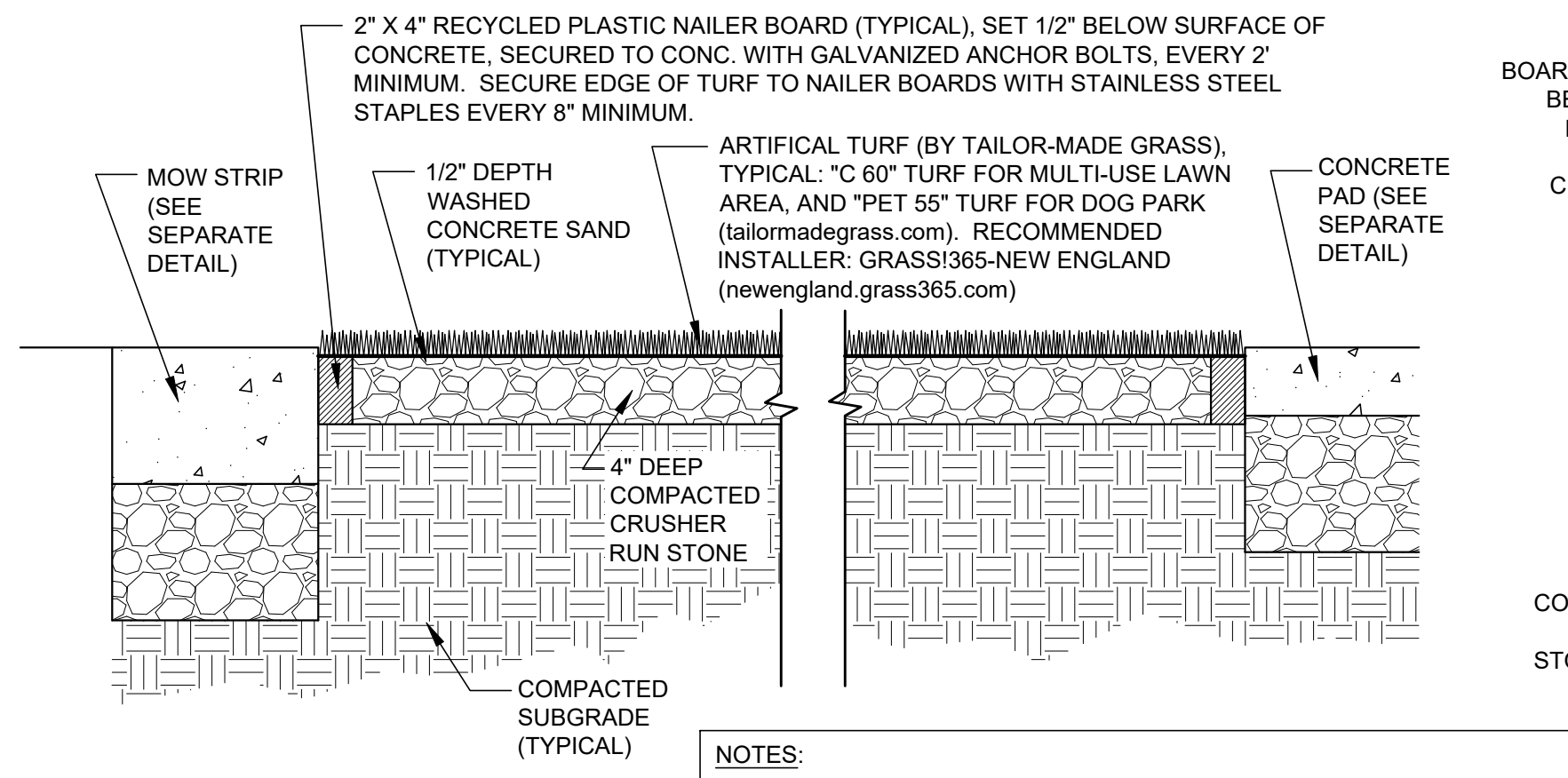
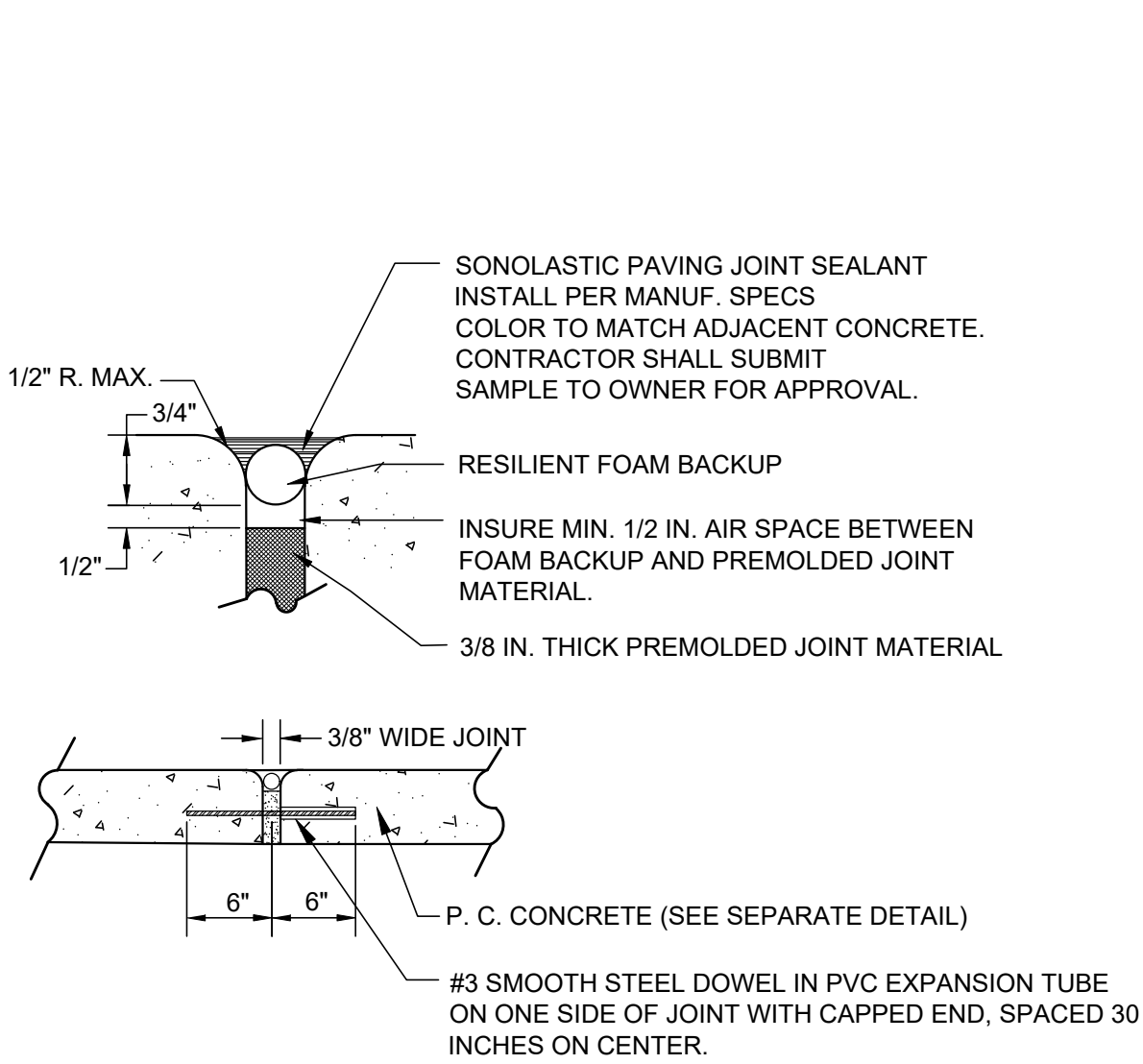

NOTES:
1) PRECAST CURB SHALL BE BY SCITUATE CONCRETE PRODUCTS (scituatecompanies.com), AND SHALL INCLUDE 2 HORIZONTAL #4 REBARS AND DOWEL PINS CONNECTING THE SEGMENTS.
2) ARTIFICIAL TURF SHALL BE INSTALLED IN ACCORDANCE WITH MANUFACTURER'S INSTRUCTIONS. INFILL FOR TURF SHALL BE MANUFACTURED SAND (WITH ROUND, SMOOTH GRAINS), APPLIED AT 3 POUNDS PER SQUARE FOOT FOR C60 TURF AND 2 POUNDS PER SQUARE FOOT FOR PET 55 TURF.

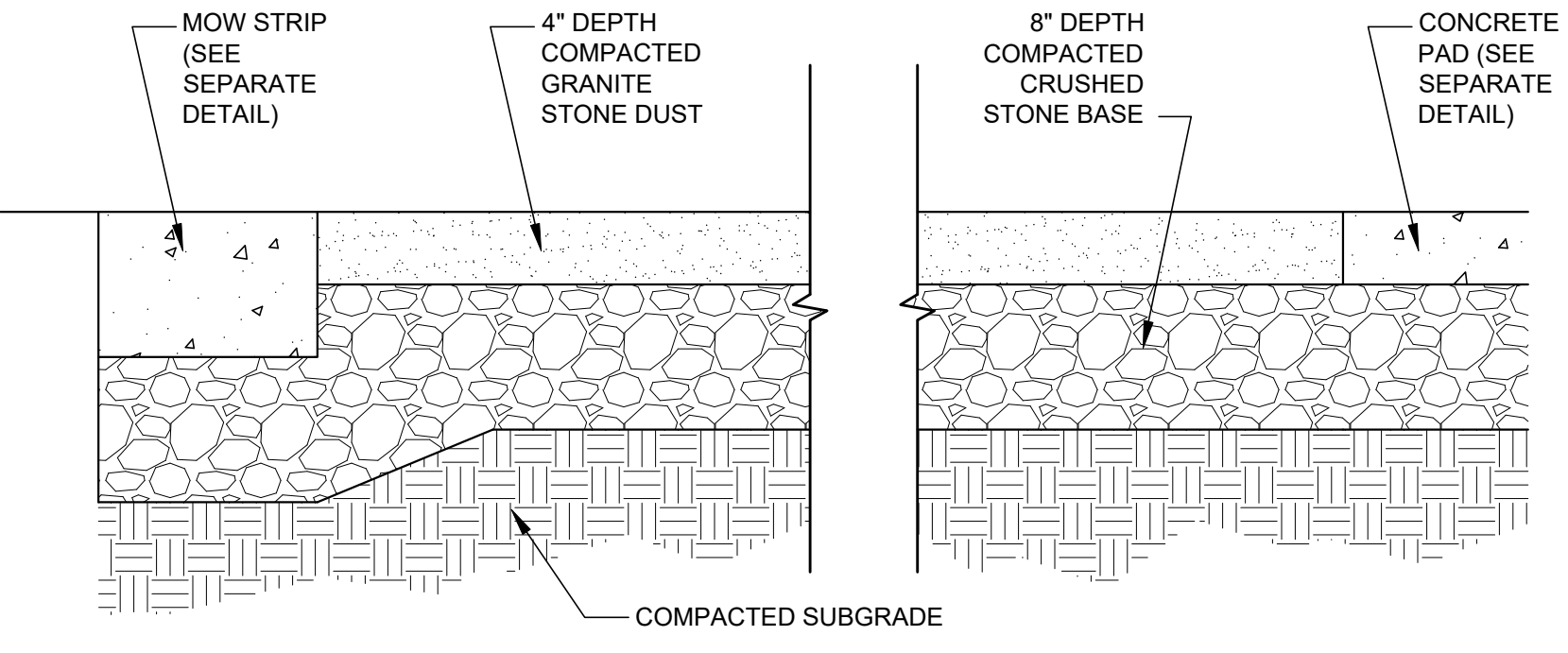
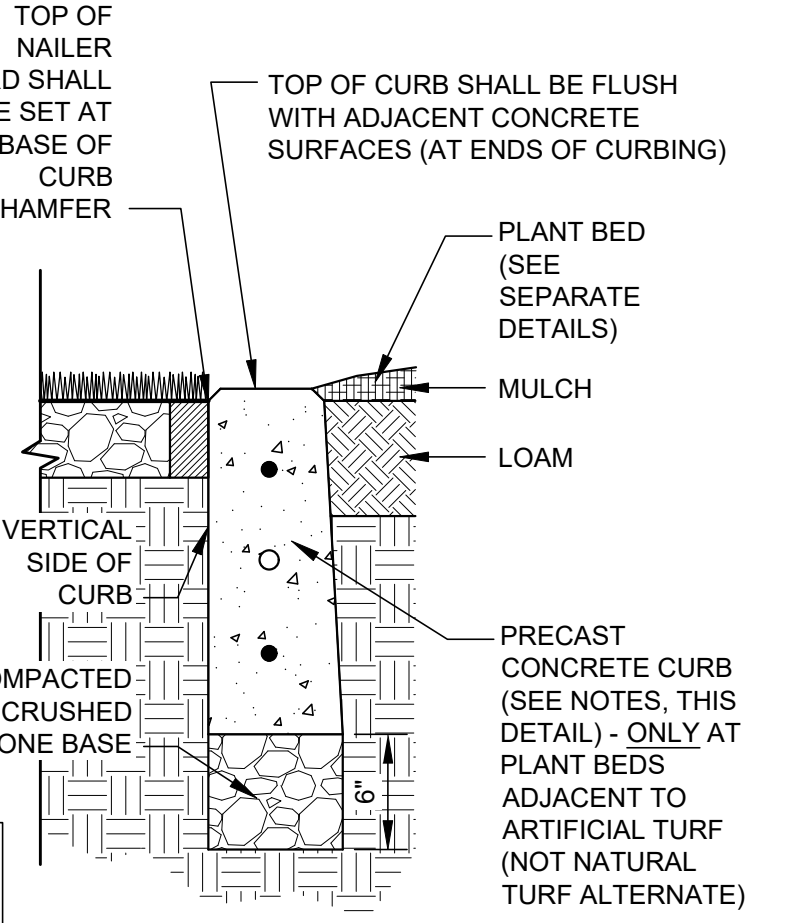

C CONCRETE EXPANSION JOINT
SECTIONS NOT TO SCALE

D ARTIFICIAL TURF
SECTIONS NOT TO SCALE

E STONE DUST SURFACING (ALTERNATE FOR DOG PARK)
SECTION NOT TO SCALE

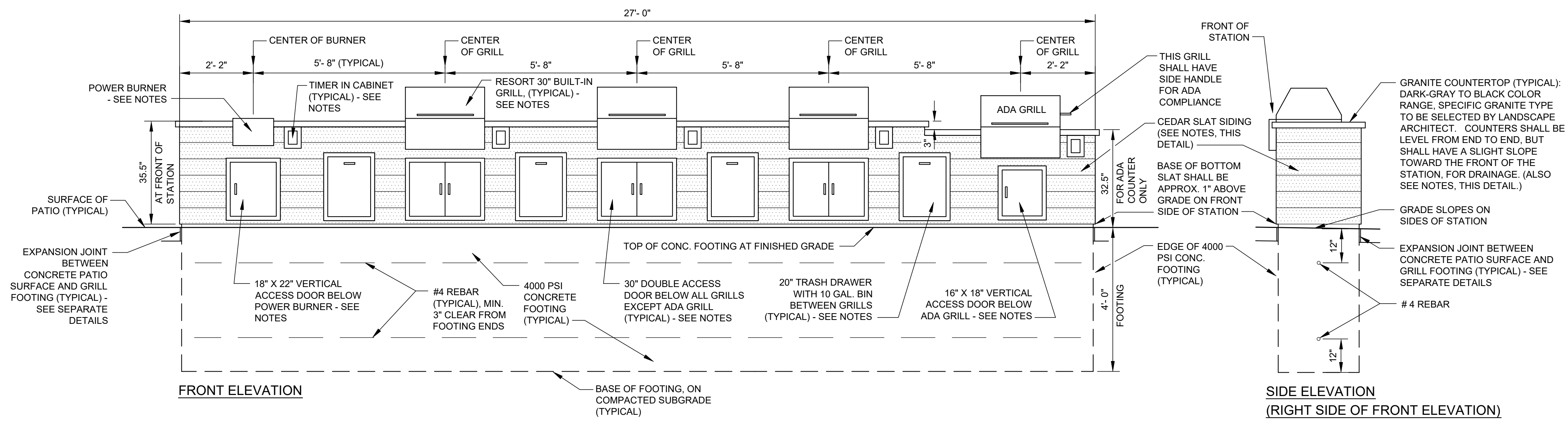

GRILL STATION NOTES:

- ALL EQUIPMENT (GRILLS, BURNER, CABINETS, TRASH DRAWER, & TIMERS) SHALL BE SUPPLIED BY SUMMERSET (WWW.SUMMERSETGRILLS.COM), LOCAL REP: # 413-210-0108. ALL GRILLS AND POWER BURNER SHALL INCLUDE INSULATED GRILL LINERS (SEE MODEL NUMBERS BELOW).
RESORT 30" BUILT-IN GRILL: MODEL # SBG30
SIZZLER PRO POWER BURNER: MODEL # SIZPROP
30" DOUBLE DOOR: MODEL # SSDD-30
18" X 22" VERTICAL DOOR: MODEL # SSDV-18
16" X 18" VERTICAL DOOR: MODEL # SSDV-16
20" TRASH DRAWER W/ 10-GAL. BIN: MODEL # SSTD1-20
GRILL LINER FOR 30" RESORT GRILLS: MODEL # GL-ALT30
GRILL LINER FOR SIZZLER PRO BURNER: MODEL # GL-SIZPROP
- GAS TIMERS SHALL BE ESTOP1-0H (1-HOUR) WITH EMERGENCY SHUTOFF, ONE PER GRILL OR BURNER. TIMERS SHALL BE HOUSED IN ESTOP-RM LOCKING CABINETS.
- GRILL STATION FRAME SHALL BE BUILT WITH KILN-DRIED WESTERN RED CEDAR, AS FOLLOWS: FRAME SHALL BE STRUCTURAL GRADE 1, AND SIDING SHALL BE 1 X 6 APPEARANCE GRADE A CLEAR, S3S MINIMUM, WITH FINISHED SIDE EXPOSED. THERE SHALL BE 1/4" GAPS BETWEEN SLATS. FINISHED SIDES OF SLATS SHALL BE STAINED WITH A SEMI-TRANSPARENT OIL-BASED STAIN, COLOR TO BE SELECTED BY LANDSCAPE ARCHITECT OR ARCHITECT (SAME STAIN FOR ALL CEDAR SLATS IN COURTYARD). SIDING SHALL BE FASTENED TO FRAME WITH 3-INCH HOT-DIPPED GALVANIZED "SPITLESS" RING-SHANK NAILS, 2 NAILS EVERY 2' MINIMUM.
- COUNTER TOP SHALL BE 2" THICK GRANITE, DARK GRAY TO BLACK COLOR RANGE (SPECIFIC COLOR TO BE SELECTED BY LANDSCAPE ARCHITECT OR ARCHITECT, AND SHALL BE THE SAME AS FOR WET BAR BENEATH PAVILION), WITH EASED EDGES, SEALED WITH WEATHER-RESISTANT SEALER. COUNTER TOP SHALL BE ADHERED TO GRILL STATION FRAME BELOW.
- CONTRACTOR SHALL SUBMIT SHOP DRAWINGS OF GRILL STATION TO LANDSCAPE ARCHITECT FOR APPROVAL PRIOR TO CONSTRUCTION.

F GRILL STATION
ELEVATION VIEWS NOT TO SCALE



PROJECT:
274 FRANKLIN ST.
WORCESTER, MA

CLIENT:
GOVENTURE
CAPITAL GROUP

DATE: 9-25-23

REVISIONS:

NO.	DATE	DESCRIPTION

SCALE: NONE

**COURTYARD
CONSTRUCTION
DETAILS**

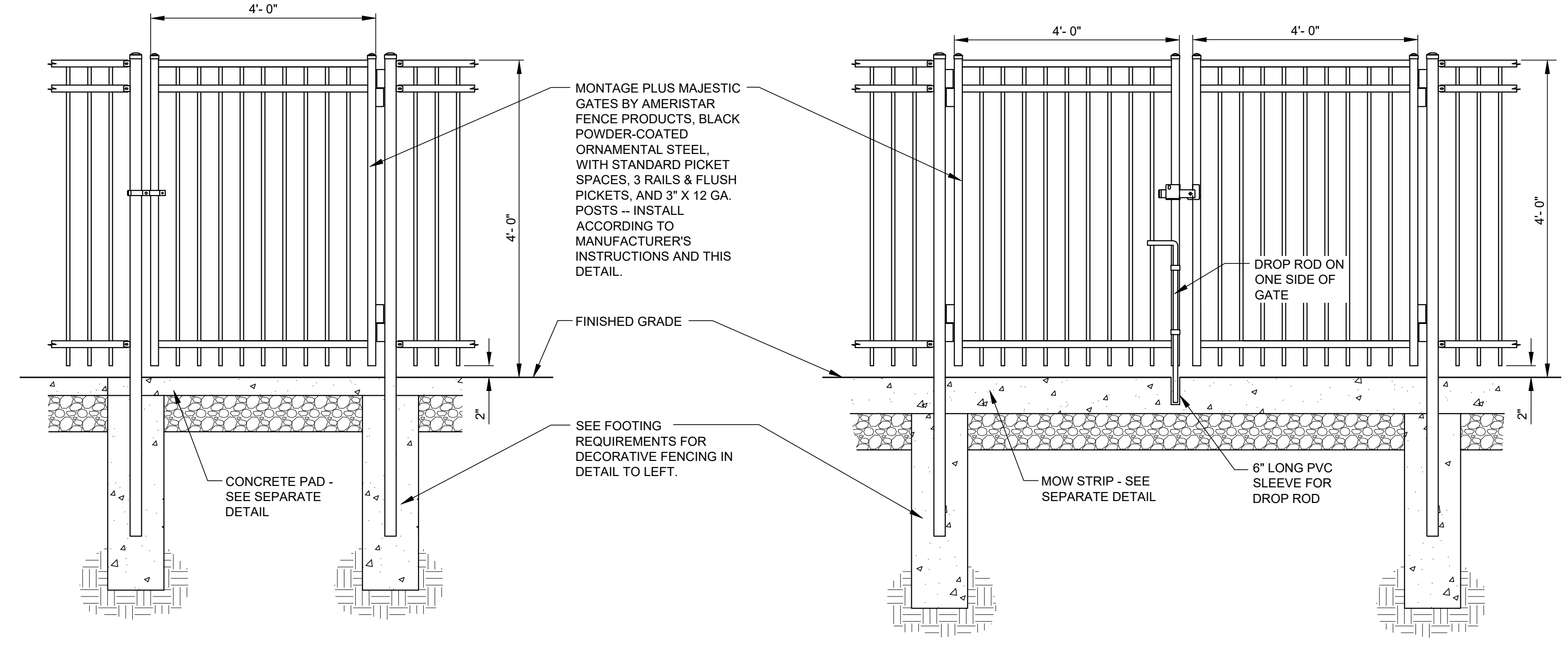
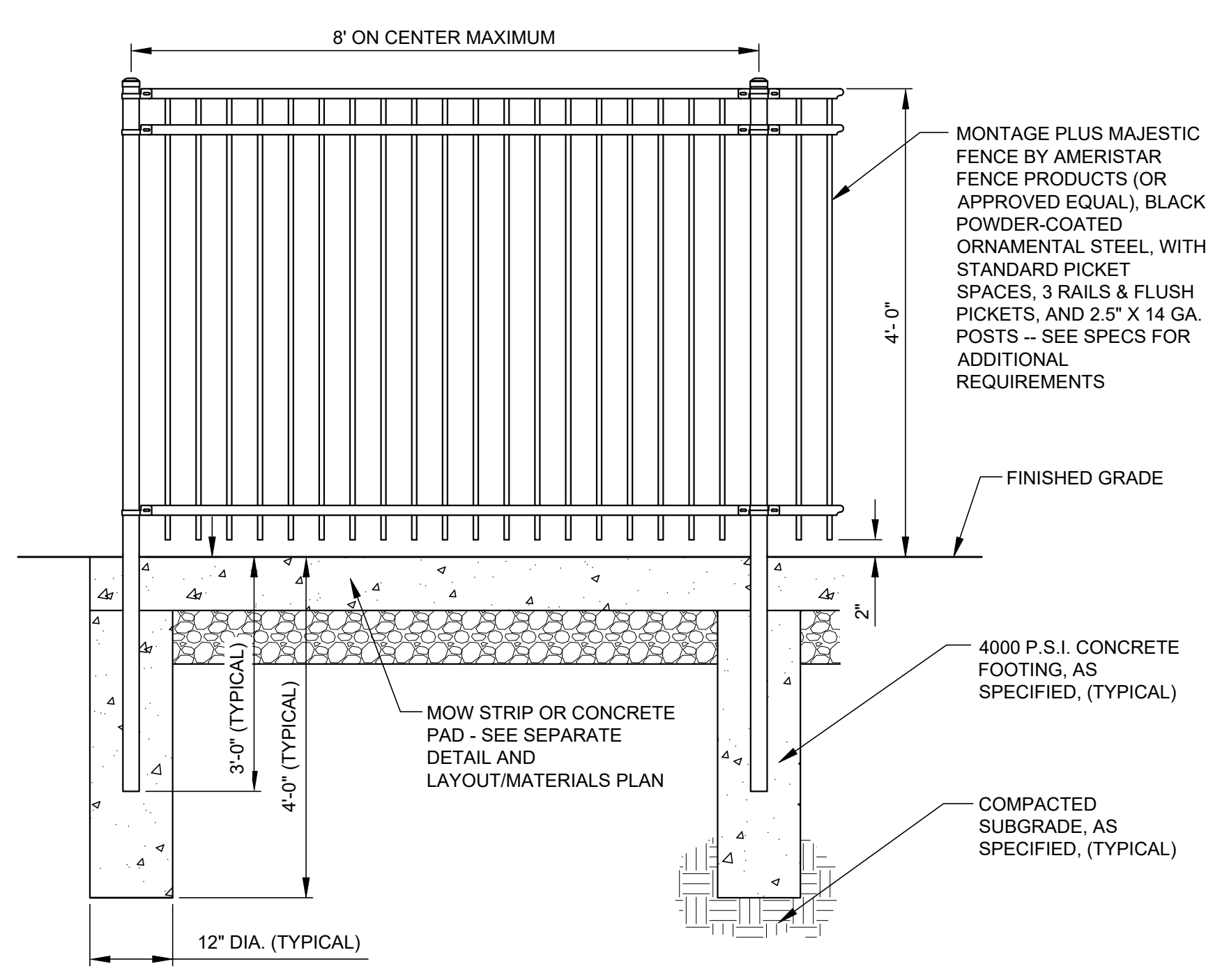

A
L8 SECTION NOT TO SCALE
ORNAMENTAL STEEL FENCE

B
L8 SECTION VIEWS NOT TO SCALE
GATES IN ORNAMENTAL STEEL FENCE



PROJECT:
 274 FRANKLIN ST.
 WORCESTER, MA

CLIENT:
 GOVENTURE
 CAPITAL GROUP

DATE: 9-25-23

REVISIONS:

NO.	DATE	DESCRIPTION

SCALE: NONE

**COURTYARD
 CONSTRUCTION
 DETAILS**

SHEET L-8 OF 10

- NOTES:**
- 1) NOT ALL FENCING INCLUDES A MOW STRIP (SOME FENCING IS WITHIN A CONCRETE PAD) -- SEE LAYOUT & MATERIALS PLAN.
 - 2) ALSO SEE SEPARATE DETAILS FOR ORNAMENTAL STEEL FENCING, ADJACENT SURFACING, AND FOR CONCRETE JOINTS (P.C. CONCRETE PAVEMENT AND EXPANSION JOINT DETAILS).
 - 3) SLOPE ACROSS EAST-WEST ORIENTED MOW STRIPS SHALL BE 1.5%, IN DIRECTION OF DOG PARK SLOPE.
 - 4) DO NOT EXTEND REBAR THROUGH EXPANSION JOINTS.

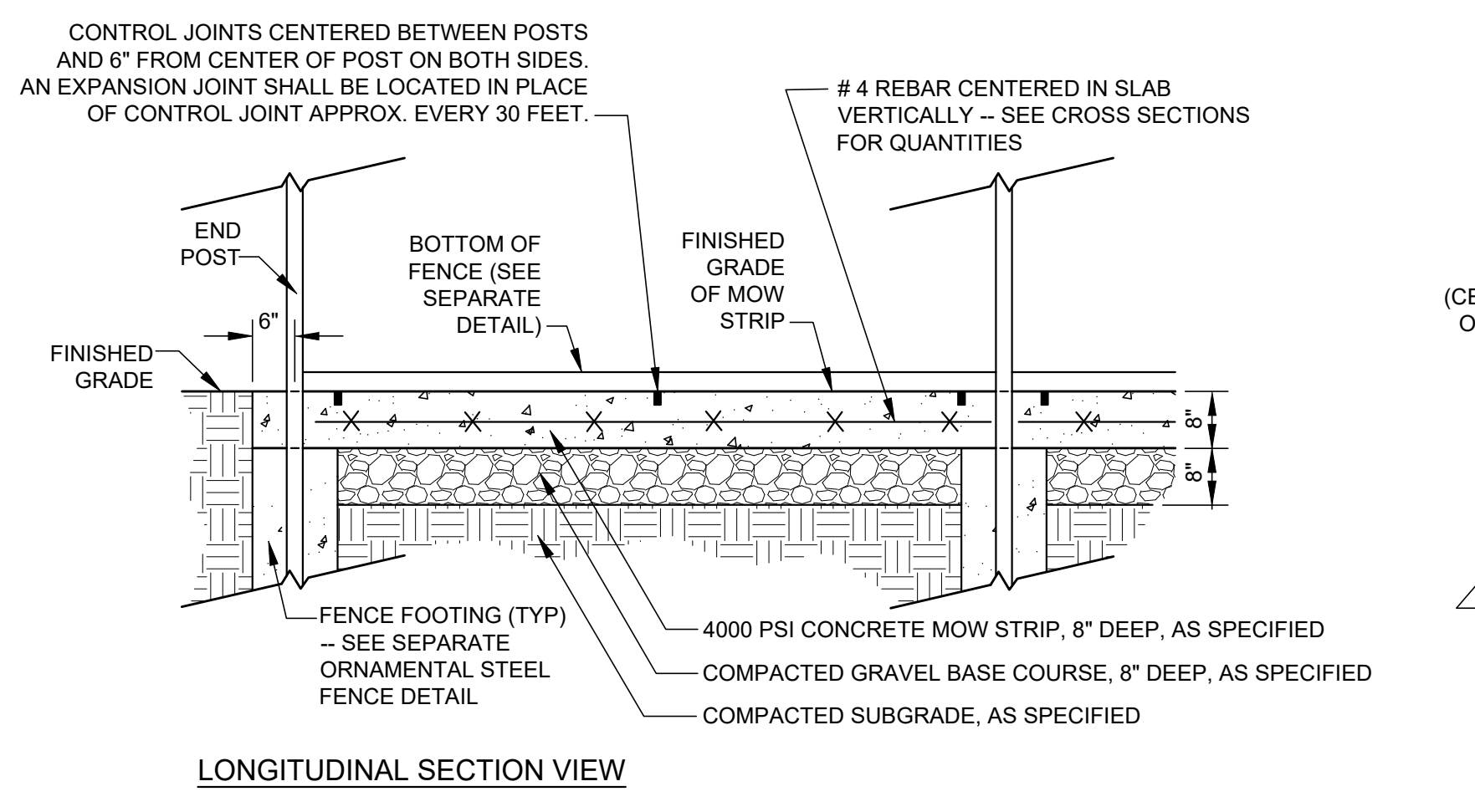

C
L8 SECTIONS NOT TO SCALE
CONCRETE MOW STRIP

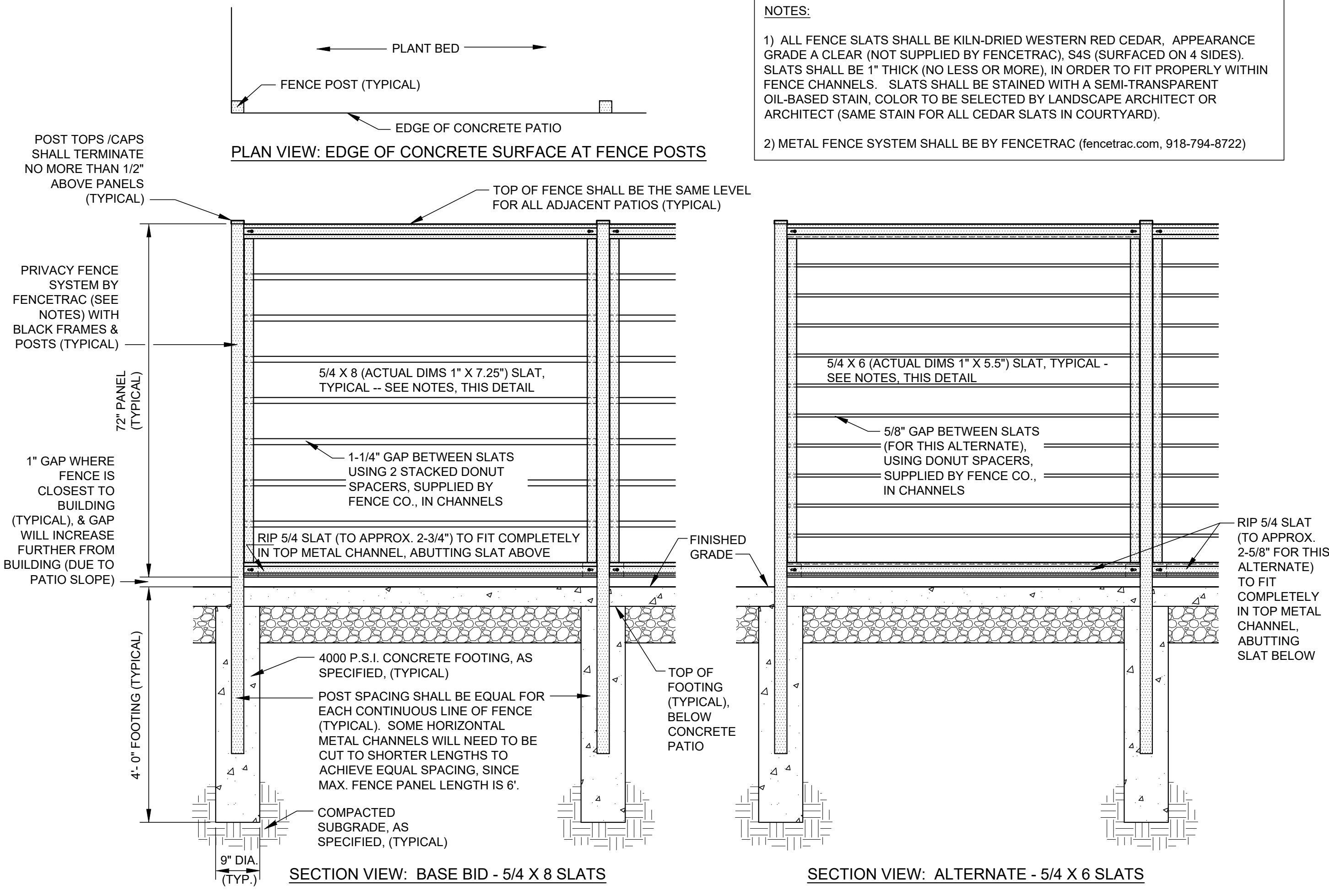

D
L8 SECTION VIEWS NOT TO SCALE
PRIVACY FENCE

- NOTES:**
- 1) ALL FENCE SLATS SHALL BE KILN-DRIED WESTERN RED CEDAR. APPEARANCE GRADE A CLEAR (NOT SUPPLIED BY FENCETRAC), S4S (SURFACED ON 4 SIDES). SLATS SHALL BE 1" THICK (NO LESS OR MORE), IN ORDER TO FIT PROPERLY WITHIN FENCE CHANNELS. SLATS SHALL BE STAINED WITH A SEMI-TRANSPARENT OIL-BASED STAIN. COLOR TO BE SELECTED BY LANDSCAPE ARCHITECT OR ARCHITECT (SAME STAIN FOR ALL CEDAR SLATS IN COURTYARD).
 - 2) METAL FENCE SYSTEM SHALL BE BY FENCETRAC (fencetrac.com, 918-794-8722)

TECHNICAL NOTES FOR EARTHWORK IN COURTYARD

1) PREPARATION

- A. THE CONTRACTOR SHALL PROTECT STRUCTURES, UTILITIES, SIDEWALKS, PAVEMENTS, AND OTHER FACILITIES FROM DAMAGE CAUSED BY SETTLEMENT, LATERAL MOVEMENT, UNDERMINING, WASHOUT, AND OTHER HAZARDS CREATED BY EARTHWORK OPERATIONS.
- B. THE CONTRACTOR SHALL PROTECT SUB-GRADES AND FOUNDATION SOILS AGAINST FREEZING TEMPERATURES OR FROST. HE/SHE SHALL PROVIDE PROTECTIVE INSULATING MATERIALS AS NECESSARY.

2) SUBGRADE AND BACKFILL COMPACTION REQUIREMENTS

- A. PERCENTAGE OF MAXIMUM DRY DENSITY REQUIREMENTS: THE CONTRACTOR SHALL COMPACT SOIL TO NOT LESS THAN THE FOLLOWING PERCENTAGES OF MAXIMUM DRY DENSITY ACCORDING TO ASTM D 1557 AND IN PLACE DENSITY IN ACCORDANCE WITH ASTM D 1556. ALL FILL AND BACKFILL MATERIAL SHALL BE COMPACTED IN LAYERS NOT TO EXCEED 6 INCHES.
- UNDER STRUCTURES, PAVEMENTS, ARTIFICIAL TURF, AND STONE DUST, THE CONTRACTOR SHALL COMPACT THE SUB-GRADE AND EACH LAYER OF BACKFILL OR FILL MATERIAL AT 95 PERCENT MAXIMUM DRY DENSITY. WHERE COMPACTION WITH LARGE EQUIPMENT IS NOT POSSIBLE DUE TO THE NARROW WIDTHS OF EXCAVATIONS, A PLATE COMPACTOR OR WALK-BEHIND DRUM ROLLER SHALL BE USED TO ACHIEVE THE REQUIRED LEVEL OF COMPACTION OF THE SUB-GRADE.
 - UNDER AREAS TO RECEIVE LOAM/SEED AND PLANTINGS, THE CONTRACTOR SHALL COMPACT THE SUB-GRADE AND EACH LAYER OF BACKFILL OR FILL MATERIAL AT 90 PERCENT MAXIMUM DRY DENSITY.
 - FOR COMPACTION BELOW UTILITIES, SEE ENGINEERING DRAWINGS & SPECS.

3) GRADING

- A. GENERAL: THE CONTRACTOR SHALL UNIFORMLY GRADE AREAS TO A SMOOTH SURFACE, FREE FROM IRREGULAR SURFACE CHANGES. HE/SHE SHALL COMPLY WITH COMPACTION REQUIREMENTS AND GRADE TO CROSS SECTIONS, LINES, AND ELEVATIONS INDICATED.
- THE CONTRACTOR SHALL PROVIDE A SMOOTH TRANSITION BETWEEN EXISTING ADJACENT GRADES AND NEW GRADES.
- B. THE CONTRACTOR SHALL CUT OUT SOFT SPOTS, FILL LOW SPOTS, AND TRIM HIGH SPOTS TO CONFORM TO PROPOSED GRADES.

TECHNICAL NOTES FOR AGGREGATE SURFACING & BASE COURSES

1) STONE DUST SURFACING: STONE DUST SHALL BE CRUSHED GRANITE, AND SHALL BE MEDIUM TO DARK GRAY WHEN WET AND CONSISTENT THROUGHOUT. THIS GRADATION OF STONE DUST SHALL BE COURSE WITH VISIBLE CHIPS, AND SHALL BE THE PRODUCT OF A STONE CRUSHER. IT SHALL CONSIST OF INERT MATERIALS THAT ARE HARD, DURABLE STONE, FREE FROM SURFACE COATINGS AND DELETERIOUS MATERIALS.

GRADATION REQUIREMENTS SHALL BE AS FOLLOWS:

U.S. SIEVE NO.	PERCENT PASSING BY WEIGHT
# 4	100
# 8	96
# 16	68
# 30	43
# 50	29
# 100	17
# 200	11

2) AGGREGATE FOR BASE COURSE: DENSE GRADED CRUSHED STONE FOR BASE COURSE SHALL BE A 3/4" CRUSHED STONE AND SHALL MEET THE REQUIREMENTS OF MA DOT SPECIFICATION SECTION M2.01.4 OF DIVISION 3 - MATERIALS.

3) PLACEMENT AND COMPACTION OF STONE DUST: THE STONE DUST SHALL BE PLACED OVER A PREVIOUSLY APPROVED AND INSTALLED COMPACTED BASE OF CRUSHED STONE AS DETAILED ON THE DRAWINGS. THE STONE DUST SHALL BE PLACED TO THE LINE AND GRADES SHOWN ON THE PLANS AND SHALL CONSIST OF A MINIMUM OF THE DETAILED THICKNESS AFTER WATERING AND COMPACTING TO NINETY-FIVE PERCENT (95%) OF THE MAXIMUM DRY DENSITY OF THE MATERIAL AS DETERMINED BY THE STANDARD AASHTO TEST DESIGNATION T99 COMPACTION TEST METHOD C AT OPTIMUM MOISTURE CONTENT AS DETERMINED BY THE LANDSCAPE ARCHITECT OR OWNER'S REPRESENTATIVE.

4) PLACEMENT AND COMPACTION OF AGGREGATE BASE COURSE: THE AGGREGATE MATERIAL SHALL BE PLACED IN LIFTS NOT TO EXCEED EIGHT (8) INCHES. EACH LAYER SHALL BE GRADED TO THE REQUIRED SECTION AND COMPACTED TO AT LEAST 95 PERCENT OF THE DENSITY AS DETERMINED BY AASHTO T180. THE BASE MATERIAL SHALL BE COMPACTED AT A MOISTURE CONTENT WHICH IS APPROXIMATELY THAT REQUIRED TO PRODUCE THE MAXIMUM DENSITY.

TECHNICAL NOTES FOR PORTLAND CEMENT CONCRETE

1) SCOPE OF WORK: THE WORK COVERED BY THIS SPECIFICATION CONSISTS OF THE SUBGRADE PREPARATION, BASE COURSE, FORM WORK, REINFORCEMENT, JOINTING, PLACING, FINISHING AND CURING OF CONCRETE WORK. ITEMS INCLUDED ARE WALKWAYS, PATIOS, MOW STRIPS, FOOTINGS, AND PLANTER WALLS.

2) INDUSTRY STANDARDS: SOME PRODUCTS AND EXECUTION METHODS ARE SPECIFIED IN THIS SECTION BY REFERENCE TO PUBLISHED SPECIFICATIONS OR STANDARDS OF THE FOLLOWING, WITH RESPECTIVE ABBREVIATIONS USED.

AASHTO: AMERICAN ASSOCIATION OF STATE HIGHWAY AND TRANSPORTATION OFFICIALS.

ACI: AMERICAN CONCRETE INSTITUTE

ASTM: AMERICAN SOCIETY FOR TESTING & MATERIALS

AWS: AMERICAN WELDING SOCIETY

PS: U. S. PRODUCT STANDARDS

MSSHB: MASSACHUSETTS STANDARD SPECIFICATIONS FOR HIGHWAYS AND BRIDGES

3) PORTLAND CEMENT CONCRETE: STANDARD WEIGHT, READY MIXED CONCRETE CONFORMING TO ASTM C94-73A AND HAVING THE FOLLOWING PROPERTIES.

- MAXIMUM SIZE AGGREGATE OF 3/4 INCH
- NON-VIBRATED SLUMP BETWEEN 2.5 AND 4 INCHES
- 4000 PSI MINIMUM COMPRESSIVE STRENGTH AT 28 DAYS
- CONCRETE SHALL BE AIR ENTRAINED TO PROVIDE AN AIR CONTENT OF 6.0 PERCENT PLUS OR MINUS 1/4 PERCENT. AIR ENTRAINING AGENTS SHALL MEET THE REQUIREMENTS OF AASHTO M154.
- WATER USED SHALL BE CLEAN AND FREE FROM OIL, SALT, ACID, ALKALI, ORGANIC MATTER, OR OTHER SUBSTANCES INJURIOUS TO THE FINISHED PRODUCT.
- MAXIMUM WATER-CEMENT RATIO OF 0.532

4) WELDED WIRE MESH: ELECTRICALLY WELDED WIRE FABRIC OR COLD DRAWN WIRE OF GAUGE AND SPACING SHOWN ON THE DRAWINGS, CONFORMING TO "SPECIFICATIONS FOR WELDED STEEL FABRIC FOR CONCRETE REINFORCEMENT", ASTM A-185-70. WELDED WIRE FABRIC SHALL BE FURNISHED IN MATS AND NOT IN ROLLS.

5) AGGREGATE FOR BASE COURSE: DENSE GRADED CRUSHED STONE FOR BASE COURSE SHALL BE A 3/4" CRUSHED STONE AND SHALL MEET THE REQUIREMENTS OF MA DOT SPECIFICATION SECTION M2.01.4 OF DIVISION 3 - MATERIALS.

6) FORMS: FORMS SHALL BE OF EITHER WOOD OR STEEL OF SIZE AND STRENGTH TO RESIST MOVEMENT DURING CONCRETE PLACEMENT AND TO RETAIN HORIZONTAL AND VERTICAL ALIGNMENT UNTIL REMOVAL. FORMS SHALL BE STRAIGHT AND FREE OF DISTORTION AND DEFECTS. BENT, TWISTING, SPLIT OR DEFECTIVE MATERIALS WILL NOT BE PERMITTED.

7) SUBGRADES:

- THE SUBGRADE SHALL BE SHAPED TO THE LINES AND GRADES ESTABLISHED BY THE DRAWINGS. ALL BOULDERS AND ALL VEGETATIVE MATTER SHALL BE REMOVED AND REPLACED WITH SUITABLE MATERIAL. SUITABLE MATERIAL SHALL COME FROM SOURCES APPROVED BY THE OWNER'S REPRESENTATIVE. THE TOP SIX (6) INCHES OF SUBGRADE, IN AREAS WITHOUT FILL, SHALL BE COMPACTED AS CLOSE AS POSSIBLE TO 100 PERCENT MAXIMUM DRY DENSITY AS DETERMINED BY AASHTO METHOD T99. FOR AREAS WITH FILL, COMPACT TO A DENSITY AS DETERMINED BY AASHTO METHOD T99. BACKFILL MATERIAL SHALL BE PLACED IN LIFTS OF EIGHT (8) INCHES OR LESS.
- THE SUBGRADE SHALL BE COMPACTED AT A MOISTURE CONTENT THAT IS APPROXIMATELY THAT REQUIRED TO PRODUCE THE MAXIMUM DENSITY INDICATED BY THE TEST METHOD NOTED ABOVE. THE CONTRACTOR SHALL DRY OR ADD MOISTURE TO THE SUBGRADE WHEN REQUIRED TO PROVIDE A UNIFORMLY COMPACTED AND ACCEPTABLE SUBGRADE.

8) PLACEMENT AND COMPACTION OF AGGREGATE BASE COURSE: THE AGGREGATE MATERIAL SHALL BE PLACED IN LIFTS NOT TO EXCEED EIGHT (8) INCHES. EACH LAYER SHALL BE GRADED TO THE REQUIRED SECTION AND COMPACTED TO AT LEAST 95 PERCENT OF THE DENSITY AS DETERMINED BY AASHTO T180. THE BASE MATERIAL SHALL BE COMPACTED AT A MOISTURE CONTENT WHICH IS APPROXIMATELY THAT REQUIRED TO PRODUCE THE MAXIMUM DENSITY.

9) FORM WORK: FORMS SHALL BE STRAIGHT, TRUE TO PLANE, PLUMB, AND SHALL BE BRACED TO PREVENT DISPLACEMENT DURING CONCRETE PLACING. FORMS SHALL BE TIGHT TO PREVENT LEAKAGE OF CONCRETE. ALL INSIDE FORM SURFACES SHALL BE THOROUGHLY COATED WITH COMMERCIAL QUALITY FORM OIL.

10) JOINTS: PROVIDE CONTROL JOINTS IN ACCORDANCE WITH THE DRAWINGS.

11) METAL REINFORCEMENT: PROVIDE METAL REINFORCEMENT IN ACCORDANCE WITH THE DRAWINGS.

12) INTEGRAL COLOR: FOR AREAS TO RECEIVE INTEGRAL COLOR, ADD COLORANT IN ACCORDANCE WITH MANUFACTURER'S INSTRUCTIONS.

13) PLACING CONCRETE:

A) PREPARATION BEFORE PLACING:

- NO CONCRETE SHALL BE PLACED UNTIL FORMS AND SUBGRADES HAVE BEEN INSPECTED BY THE OWNER'S REPRESENTATIVE.
- BEFORE CONCRETE IS PLACED, CLEAN ALL MIXING AND TRANSPORTING EQUIPMENT, AND REMOVE DEBRIS, ICE, WATER, AND DELETERIOUS MATERIAL FROM FORMS AND REINFORCEMENT THAT WOULD AFFECT QUALITY OR APPEARANCE OF CONCRETE, OR INHIBIT BOND OF CONCRETE TO REINFORCING.
- PROVIDE RUNWAYS AND ACCESS TO AREAS TO BE PLACED WHICH WILL PROTECT FORMS AND REINFORCEMENT FROM DISPLACEMENT.
- PLACE CONCRETE ON A FIRM, DRY SUBGRADE. IN NO CASE PLACE CONCRETE ON FROZEN SUBGRADE.

B) CONVEYING: CONVEY CONCRETE FROM MIXER TO PLACE OF FINAL DEPOSIT BY METHODS THAT WILL PREVENT SEPARATION OR LOSS OF MATERIALS. EQUIPMENT FOR CONVEYING CONCRETE SHALL BE OF SUCH SIZE AND DESIGN AS TO INSURE A PRACTICALLY CONTINUOUS FLOW OF CONCRETE FROM DELIVERY END TO POINT OF DEPOSIT WITHOUT SEPARATION OF MATERIALS.

C) DEPOSITING:

- DO NOT MIX NOR POUR CONCRETE WHEN ATMOSPHERIC TEMPERATURE IS BELOW 40 DEGREES F., NOR WHEN SUCH TEMPERATURES ARE EXPECTED WITHIN TWO DAYS.
- DEPOSIT CONCRETE AS NEARLY AS PRACTICABLE IN ITS FINAL POSITION TO AVOID SEGREGATION DUE TO RE-HANDLING OR FLOWING. MAXIMUM FREE FALL OF CONCRETE SHALL BE 3 FEET.
- DEPOSIT CONCRETE AT A RATE SO THAT CONCRETE IS PLASTIC AT ALL TIMES, AND IS BEING INTEGRATED WITH CONCRETE THAT IS STILL PLASTIC. DEPOSIT CONTINUOUSLY UNTIL CONCRETE WORK BETWEEN CONSTRUCTION JOINTS IS COMPLETE.
- CONSOLIDATE CONCRETE THOROUGHLY BY SUITABLE MEANS DURING PLACEMENT. WORK THOROUGHLY AROUND REINFORCEMENT AND EMBEDDED ITEMS, AND INTO CORNERS OF FORMS.
- SPADE CONCRETE THOROUGHLY ALONG FORMS AND EXPANSION JOINTS.
- WHERE SURFACE MORTAR IS BASIS OF FINISH OF CONCRETE, WORK COARSE AGGREGATE BACK FROM FORMS WITHOUT FORMATION OF SURFACE VOIDS.
- VIBRATORS MAY BE USED PROVIDED THEY ARE USED BY EXPERIENCED OPERATORS, AND PROVIDED FORMS HAVE BEEN DESIGNED AGAINST DEFLECTION AND DISPLACEMENT BY VIBRATED CONCRETE.
- TAMP AND SCREED CONCRETE TRUE TO GRADE AND SECTION. DO NOT TROWEL CONCRETE (AFTER DARBYING) UNTIL SURFACE WATER HAS EVAPORATED.

14) FINISHING SURFACES: AFTER SCREEDING AND CONSOLIDATING SLABS, DO NOT WORK SURFACE UNTIL READY FOR FLOATING. SPRINKLING DRY CEMENT, OR MIXTURE OF DRY CEMENT AND SAND, IS NOT PERMITTED. BEGIN FLOATING WHEN WATER SHEEN HAS DISAPPEARED, AND/OR MIX HAS STIFFENED SUFFICIENTLY TO PERMIT THE OPERATION OF POWER-DRIVEN FLOATS. CHECK AND LEVEL SURFACE LINE TO A TOLERANCE NOT EXCEEDING 1/4 INCH IN 10 FEET WHEN TESTED WITH A 10-FOOT STRAIGHTEDGE. CUT DOWN HIGH SPOTS AND FILL LOW SPOTS. UNIFORMLY SLOPE SURFACES. FOR SURFACES TO RECEIVE STAMPS, APPLY COLORLESS BOND-BREAKER, STAMPS, AND SEALER IN ACCORDANCE WITH MANUFACTURER'S INSTRUCTIONS. FOR WALKWAYS AND PADS (TO RECEIVE FINE BROOM FINISH), IMMEDIATELY AFTER TROWEL FINISHING, SLIGHTLY ROUGHEN CONCRETE SURFACE BY BROOMING WITH FIBER BRISTLE BROOM PERPENDICULAR TO MAIN DIRECTION OF PEDESTRIAN TRAFFIC, OR IN ACCORDANCE WITH THE DRAWINGS.

15) REMOVAL OF FORMS: AFTER A MINIMUM OF 24 HOURS REMOVE FORMS CAREFULLY. DO NOT DAMAGE FACE OF CONCRETE OR CHIP TOOLED EDGE.

16) STAINING PLANTER WALLS: EXPOSED SURFACES OF PLANTER WALLS SHALL RECEIVE ONE COAT OF WATER-BASED MASONRY STAIN, COLOR TO BE SELECTED BY THE LANDSCAPE ARCHITECT.

17) CONCRETE SURFACE REPAIRS: REPAIR AND PATCH DEFECTIVE AREAS WITH CEMENT MORTAR IMMEDIATELY AFTER REMOVAL OF FORMS, BUT ONLY WHEN ACCEPTABLE TO THE OWNER'S REPRESENTATIVE. CUT OUT HONEYCOMB, ROCK POCKETS, VOIDS OVER 1/2 INCH DIAMETER, AND HOLES LEFT BY THE RODS DOWN TO SOLID CONCRETE, BUT IN NO CASE TO A DEPTH OF LESS THAN 1 INCH. ALSO REMOVE FINS AND OTHER PROJECTIONS ON SURFACE AND STAINS AND OTHER DISCOLORATIONS THAT CANNOT BE REMOVED BY CLEANING. BEFORE PLACING CEMENT MORTAR, THOROUGHLY CLEAN, DAMPEN WITH WATER AND BRUSH-COAT THE AREA TO BE PATCHED WITH NEAT CEMENT GROUT. PROPRIETARY PATCHING COMPOUNDS MAY BE USED WHEN ACCEPTABLE TO THE OWNER'S REPRESENTATIVE. REMOVE AND REPLACE CONCRETE HAVING DEFECTIVE SURFACES IF DEFECTS CANNOT BE REPAIRED TO THE SATISFACTION OF THE OWNER'S REPRESENTATIVE.

18) PROTECTION AND CURING: ALL EXPOSED SURFACES OF CONCRETE SHALL BE PROTECTED FROM PREMATURE DRYING. FRESHLY PLACED CONCRETE SHALL BE PROTECTED AGAINST WASH BY RAIN AND AGAINST VANDALISM. FOR CONCRETE AREAS INTENDED FOR VEHICULAR TRAFFIC, NO TRAFFIC SHALL BE ALLOWED ON CONCRETE FOR A PERIOD OF 14 DAYS AFTER POURING. THE CONTRACTOR SHALL REMOVE AND REPLACE ANY DAMAGED CONCRETE AS DIRECTED BY THE OWNER'S REPRESENTATIVE AND THESE SPECIFICATIONS.



280 BEVERLY ROAD ■ WORCESTER, MA 01605
508-852-2644 ■ info@edlandarcht.com



PROJECT:
274 FRANKLIN ST.
WORCESTER, MA

CLIENT:
GOVENTURE
CAPITAL GROUP

DATE: 9-25-23

REVISIONS:

NO.	DATE	DESCRIPTION

SCALE: NONE

**COURTYARD
CONSTRUCTION
NOTES**

SHEET L-9 OF 10

TECHNICAL NOTES FOR LOAM BORROW:

- 1) **SCOPE OF WORK:** FOR THIS PROJECT, THE WORK SHALL INCLUDE PLACING LOAM ALL AREAS TO RECEIVE PLANTS AND TURFGRASS SEEDING.
- 2) THE CONTRACTOR SHALL FURNISH A CERTIFIED LABORATORY REPORT SHOWING THE SOILS CLASSIFICATION AND NUTRIENT ANALYSIS OF REPRESENTATIVE SAMPLES OF THE LOAM THIS IS PROPOSED TO BE USED, INCLUDING THE EXTENT OF LIME AND FERTILIZER REQUIRED. ALL COSTS FOR SUCH WORK SHALL BE BORNE BY THE CONTRACTOR.
- 3) IN ACCORDANCE WITH THE SPECIFIC REQUIREMENTS OF THIS PROJECT, EXISTING ON-SITE SOIL MAY BE RE-USED AS LOAM BORROW ONLY IF IT MEETS THIS SPECIFICATION. EXISTING TOPSOIL THAT DOES NOT MEET THIS SPECIFICATION MAY BE RE-USED ONLY UP TO THE SUBGRADE ELEVATION WITHIN THE LIMITS OF AREAS TO RECEIVE NEW LOAM BORROW. THE CONTRACTOR SHALL FURNISH ALL REQUIRED LOAM BORROW, FROM OFF-SITE SOURCES, AS NECESSARY, TO COMPLETE THE PROJECT.
- 4) SCREENED LOAM SHALL BE "FINE SANDY LOAM" OR "SANDY LOAM" DETERMINED BY MECHANICAL ANALYSIS (ASTM D-422) AND BASED ON THE "USDA CLASSIFICATION SYSTEM". SCREENED LOAM SHALL HAVE THE FOLLOWING MECHANICAL ANALYSIS:

TEXTURAL CLASS PERCENTAGE	PERCENTAGE OF TOTAL WEIGHT	AVERAGE PERCENTAGE
SAND (0.05 - 2.0 MM)	45 - 75	60
SILT (0.002 - 0.05 MM)	5 - 35	25
CLAY (LESS THAN 0.002 MM)	5 - 20	15
- 5) SCREENED LOAM SHALL BE A NATURAL PRODUCT CONSISTING PRIMARILY OF NATURAL TOPSOIL, FREE FROM SUBSOIL, AND OBTAINED FROM AN AREA THAT HAS NEVER BEEN STRIPPED BEFORE. SCREENED LOAM SHALL NOT CONTAIN LESS THAN FIVE PERCENT (5%) NOR MORE THAN TEN PERCENT (10%) ORGANIC MATTER. TO ADJUST ORGANIC MATTER CONTENT, THE SOIL MAY BE AMENDED, PRIOR TO SITE DELIVERY, BY THE ADDITION OF COMPOSTED LEAF MOLD OR PEAT MOSS. NO MIXING OR AMENDING OF LOAM IS PERMITTED ON SITE.
- 6) THE LOAM SHALL NOT BE DELIVERED IN A WET OR FROZEN CONDITION.
- 7) SCREENED LOAM SHALL CONSIST OF FERTILE, FRIABLE, LOAM CAPABLE OF SUSTAINING VIGOROUS PLANT GROWTH. LOAM SHALL BE WITHOUT ADMIXTURE OF SUBSOIL AND REFUSE. IT SHALL BE A HOMOGENEOUS MATERIAL FREE OF STONES GREATER THAN ONE-HALF (1/2) INCH IN THE LONGEST DIMENSION; FREE OF LUMPS, PLANTS, GRASS, ROOTS, STICKS, EXCESSIVE STONE CONTENT, DEBRIS, AND EXTRANEIOUS MATTER AS DETERMINED BY THE OWNER.
- 8) SCREENED LOAM SHALL BE WITHIN THE PH RANGE OF 6.0 TO 6.5. IT SHALL BE UNCONTAMINATED BY SALT WATER, FOREIGN MATTER, AND SUBSTANCES HARMFUL TO PLANT GROWTH. THE MAXIMUM SOLUBLE SALT INDEX SHALL BE 100. SCREENED LOAM SHALL NOT HAVE LEVELS OF ALUMINUM GREATER THAN 200 PARTS PER MILLION.
- 9) SEE TURFGRASS NOTES FOR LIME AND FERTILIZER REQUIREMENTS FOR LAWN AREAS.
- 10) TOPSOIL STRUCTURE SHALL NOT BE DESTROYED THROUGH EXCESSIVE AND UNNECESSARY HANDLING OR COMPACTION. INAPPROPRIATE HANDLING LEADING TO THE COMPACTION OF DETERIORATION OF SOIL STRUCTURE WILL RESULT IN REJECTION OF TOPSOIL FOR USE.
- 11) AT NO TIME SHALL EQUIPMENT OR MATERIAL REST ON THE SOIL.
- 12) THE CONTRACTOR SHALL FURNISH AND SPREAD LOAM TO A MINIMUM 6 INCH DEPTH (AFTER SOIL SETTLEMENT) IN ALL LAWN AND PLANT BED AREAS. SUBSOIL SHALL BE SCARIFIED PRIOR TO PLACEMENT OF LOAM. THE TOP OF THE SETTLED LOAM BORROW LAYER SHALL BE TO GRADES SPECIFIED ON THE DRAWINGS. NO COMPACTION SHALL BE REQUIRED BEYOND THAT EXTENT NECESSARY TO PLACE SOD OR OR TO PLANT TREES AND SHRUBS TO ENSURE AGAINST UNEVENNESS OR SETTLING BELOW ACCEPTED GROWTH LINES.

TECHNICAL NOTES FOR PLANTINGS:

- 1) **NOMENCLATURE:** THE NAMES OF PLANTS REQUIRED UNDER THIS CONTRACT SHALL CONFORM TO THOSE GIVEN IN STANDARDIZED PLANT NAMES, LATEST EDITION, PREPARED BY THE AMERICAN JOINT COMMITTEE ON HORTICULTURAL NOMENCLATURE. NAMES OF VARIETIES NOT INCLUDED THEREIN SHALL CONFORM GENERALLY WITH NAMES ACCEPTED IN THE NURSERY TRADE.
- 2) **QUALITY AND SIZE:** PLANTS SHALL HAVE A HABIT OF GROWTH THAT IS NORMAL FOR THE SPECIES AND SHALL BE SOUND, HEALTHY, VIGOROUS, AND FREE FROM INSECT PESTS, PLANT DISEASES, AND INJURIES. ALL PLANTS SHALL EQUAL OR EXCEED THE MEASUREMENTS SPECIFIED IN THE PLANT LIST, WHICH ARE MINIMUM ACCEPTABLE SIZES. THEY SHALL BE MEASURED BEFORE PRUNING IS DONE AT TIME OF PLANTING. REQUIREMENTS FOR THE MEASUREMENTS, BRANCHING, GRADING, QUALITY, BALLING, AND BURLAPPING OF PLANTS IN THE PLANT LIST SHALL FOLLOW THE CODE OF STANDARDS CURRENTLY RECOMMENDED BY THE AMERICAN ASSOCIATIONS OF NURSERYMEN, INC., IN "THE AMERICAN STANDARD FOR NURSERY STOCK".
- 3) **SUBSTITUTIONS:** SUBSTITUTIONS WILL BE PERMITTED ONLY UPON SUBMISSION OF PROOF THAT ANY PLANT AS SPECIFIED IS NOT OBTAINABLE DURING THE SCHEDULED PLANTING SEASON. WRITTEN AUTHORIZATION BY THE LANDSCAPE ARCHITECT SHALL BE REQUIRED FOR ANY SUBSTITUTION. THE NEAREST EQUIVALENT SIZE OR VARIETY OF PLANT HAVING THE SAME ESSENTIAL CHARACTERISTICS SHALL BE PROPOSED FOR SUBSTITUTION.
- 4) **BALLED AND BURLAPPED MATERIALS:** PLANTS DESIGNATED "B&B" IN THE PLANT LIST SHALL BE BALLED AND BURLAPPED. THEY SHALL BE DUG WITH FIRM, NATURAL BALLS OF EARTH OF SUFFICIENT DIAMETER AND DEPTH TO ENCOMPASS THE FIBROUS AND FEEDING ROOT SYSTEM NECESSARY FOR FULL RECOVERY OF THE PLANT. MATERIAL SHALL BE IN A CONDITION WHERE THE NATURAL ROOT COLLAR OF THE PLANT IS WITHIN APPROXIMATELY TWO (2) INCHES OF THE SOIL LEVEL OF THE BALL. BALLS SHALL BE FIRMLY WRAPPED WITH BURLAP OR SIMILAR MATERIAL AND BOUND WITH TWINE, CORD, OR WIRE MESH. NO SYNTHETIC FABRIC IS ALLOWED. WHERE NECESSARY TO PREVENT BREAKING OR CRACKING OF THE BALL DURING THE PROCESS OF PLANTING, THE BALL MAY BE SECURED TO A PLATFORM. BALLS SHALL BE KEPT MOIST AND SHADED UNTIL THEY ARE PLANTED. REMOVE ALL BALL TIES OR STRAPPING FROM ROOT BALL PRIOR TO PLANTING. PLANT IN ACCORDANCE WITH TREE AND SHRUB PLANTING DETAILS. BALLED AND BURLAPPED TREES SHALL ONLY BE DUG IN THE SPRING.
- 5) **CONTAINER-GROWN MATERIALS:** PLANTS NOT DESIGNATED OTHERWISE IN THE PLANT LIST MAY BE PURCHASED AS CONTAINER-GROWN OR BALLED/BURLAPPED. CONTAINER-GROWN PLANTS, IF STORED ON THE SITE, SHALL BE WATERED THOROUGHLY AT LEAST ONCE EVERY 48 HOURS. ROOT SYSTEMS OF CONTAINER-GROWN PLANTS SHALL BE WELL-DEVELOPED BUT NOT IN "POT-BOUND" CONDITION OF DENSE, ENCIRCLING ROOTS. THE ROOT BALL OF THE PLANT SHALL BE LOOSENEED TO ALLEVIATE ENCIRCLING ROOTS AND TO PROVIDE AN INCREASED ROOT INTERFACE WITH THE FILL SOIL. PLANT IN ACCORDANCE WITH TREE, SHRUB, AND GROUND COVER PLANTING DETAILS. CONTAINER-GROWN TREES SHALL ONLY BE PLANTED IN THE FALL (SEPTEMBER - OCTOBER).
- 6) **PROTECTION OF PLANTS PRIOR TO INSTALLATION:** THE ROOT ZONE OF ALL PLANTS NOT YET INSTALLED SHALL BE PROTECTED FROM FREEZING, DRYING, AND DIRECT SUNLIGHT.
- 7) **MULCHING:** DOUBLE-SHREDDED HARDWOOD MULCH SHALL BE USED AS THE MULCH FOR ALL PLANT BEDS INDICATED ON THE LANDSCAPE PLAN, INCLUDING AREAS SURROUNDING THE PLANTS AS SHOWN ON THE TREE, SHRUB, AND GROUND COVER PLANTING DETAILS.
- 8) **PLANTING SEASON:** THE NORMAL PLANTING SEASON IS APRIL THROUGH NOVEMBER. SOME PLANTS SPECIFIED AS BALLED AND BURLAPPED CANNOT BE DUG DURING PORTIONS OF THIS PLANTING SEASON - CHECK WITH NURSERIES FOR SPECIFICS. PLANTING OPERATIONS SHALL BE CONDUCTED UNDER FAVORABLE WEATHER CONDITIONS DURING THE NORMAL PLANTING SEASON.
- 9) **WEATHER CONDITIONS:** PLANTING SHALL NOT TAKE PLACE WHEN SOILS ON SITE ARE FROZEN OR WET AND IN POOR TILT.
- 10) **LAYOUT:** NEW PLANTINGS SHALL BE LOCATED ACCORDING TO THE LANDSCAPE PLAN. THE CONTRACTOR SHALL STAKE THE PLANT LOCATIONS, AND SHALL THEN CONTACT THE LANDSCAPE ARCHITECT FOR APPROVAL.
- 11) **SETTING PLANTS:** ALL PLANTS SHALL BE PLANTED IN PREPARED SOILS BEDS, AND SET ON FIRM SOIL TO SUCH DEPTH AS INDICATED IN THE PLANTING DETAILS. TREES, SHRUBS, GROUND COVERS, AND PERENNIALS SHALL BE SET SO THAT THE PLANTS NATURAL ROOT COLLAR OR CROWN IS ABOVE FINISHED GRADE AT THE HEIGHTS INDICATED IN THE PLANTING DETAILS. NO BURLAP SHALL BE PULLED FROM UNDER THE BALLS. ROOTS ON BARE-ROOT PLANTS SHALL BE SPREAD IN THEIR NORMAL POSITION. ALL BROKEN OR FRAVED ROOTS SHALL BE CUT OFF CLEANLY. PREPARED SOIL SHALL BE PLACED AND COMPACTED CAREFULLY TO AVOID INJURY TO ROOTS; TO FILL ALL VOIDS, AND TO MINIMIZE ROCKING OF ROOT BALL. ADD WATER AND TAMP THE BACKFILL UNTIL THE BACKFILL IS COMPLETELY SATURATED. THEN ALLOW IT TO SOAK AWAY. FILL THE HOLE TO FINISHED GRADE, AND FORM A SAUCER AROUND EACH TREE AND SHRUB BY PLACING A RIDGE OF TOPSOIL AROUND THE EDGE OF EACH ROOT BALL, IN ACCORDANCE WITH THE PLANTING DETAILS. AFTER THE GROUND SETTLES, ADDITIONAL SOIL SHALL BE FILLED IN TO THE LEVEL OF THE FINISHED GRADE, AND WATERED.
- 12) **STAKING TREES:** DO NOT STAKE TREES, UNLESS TREES ARE PLANTED ON STEEP SLOPES, IN WHICH CASE THE CONTRACTOR SHALL CONTACT THE LANDSCAPE ARCHITECT FOR PERMISSION TO STAKE THOSE TREES.
- 13) **MAINTENANCE:** MAINTAIN PLANTS AND PLANT BEDS FROM THE TIME OF INSTALLATION UNTIL THE FINAL INSPECTION IMMEDIATELY PRIOR TO COMMENCEMENT OF THE GUARANTEE PERIOD. MAINTENANCE SHALL INCLUDE WATERING AND PROTECTION OF PLANTINGS AND OTHER NECESSARY OPERATIONS.
- 14) **FINAL INSPECTION:** WHEN THE TREE AND SHRUB PLANTINGS ARE READY FOR FINAL INSPECTION, ALL MULCHED AREAS SHALL BE FREE FROM WEEDS AND MULCHED TO THE EXTENT INDICATED ON THESE DRAWINGS. PLANT TAGS SHALL BE REMOVED BY THE CONTRACTOR PRIOR TO THE INSPECTION FOR ACCEPTANCE.
- 15) **GUARANTEE:** AFTER ACCEPTANCE AT TIME OF FINAL INSPECTION, ALL PLANTS SHALL BE GUARANTEED FOR ONE (1) YEAR. PLANTINGS SHALL BE ALIVE AND IN SATISFACTORY VIGOR AT THE END OF THE GUARANTEE PERIOD.
- 16) **REPLACEMENT:** AT THE END OF THE GUARANTEE PERIOD, ANY PLANT REQUIRED UNDER THIS CONTRACT THAT IS DEAD OR IN POOR VIGOR SHALL BE REMOVED FROM THE SITE. THESE AND ANY MISSING PLANTS SHALL BE REPLACED AS SOON AS CONDITIONS PERMIT, BUT DURING THE NORMAL PLANTING SEASON. ALL REPLACEMENTS SHALL BE PLANTS OF THE SAME KIND AS ORIGINALLY PLANTED AND SHALL BE OF SIZE EQUAL TO THAT ATTAINED BY ADJACENT PLANTS OF THE SAME KIND AT THE TIME REPLACEMENT IS MADE. ONLY ONE REPLACEMENT WILL BE REQUIRED FOR EACH PLANT DECLARED DEAD, IN AN UNHEALTHY OR BADLY IMPAIRED CONDITION, OR MISSING AT THE TIME OF FINAL INSPECTION.

TECHNICAL NOTES FOR TURFGRASS SEEDING:

- 1) **SCOPE OF WORK:** FOR THIS PROJECT, THE WORK SHALL INCLUDE SEEDING AREAS WHERE NOTED ON THE PLANS, AND TURF AREAS DISTURBED BY CONSTRUCTION.
- 2) ALL AREAS SHALL BE SEEDED WITHIN 30 DAYS AFTER FINISHED GRADES ARE ESTABLISHED AND OTHER ELEMENTS INCLUDED IN THIS CONTRACT ARE CONSTRUCTED.
- 3) **TURFGRASS SEED SPECIFICATIONS:**
 - B) AREAS RECEIVING FULL SUN OR PART SHADE

FESCUE/BUEGRASS/PERENNIAL RYEGRASS MIXTURE:
MIXTURE REQUIREMENTS ARE AS FOLLOWS (WITH APPROXIMATE PERCENTAGES):

35% FINE FESCUE (ENDOPHYTIC)
35% KENTUCKY BLUEGRASS
30% PERENNIAL RYEGRASS (ENDOPHYTIC)
 - C) AREAS RECEIVING MOSTLY SHADE (INCLUDING THE COURTYARD LAWN AREA):

FESCUE/PERENNIAL RYEGRASS MIXTURE:
MIXTURE REQUIREMENTS ARE AS FOLLOWS (WITH APPROXIMATE PERCENTAGES):

90% FINE FESCUE (ENDOPHYTIC)
10% PERENNIAL RYEGRASS (ENDOPHYTIC)
 - D) ANY PROPOSED SUBSTITUTIONS SHALL BE PRESENTED TO THE LANDSCAPE ARCHITECT FOR APPROVAL PRIOR TO SEEDING.
 - E) ALL TURFGRASS SEED SHALL HAVE A MINIMUM PURITY OF 98 PERCENT AND A GERMINATION RATE OF 85 PERCENT.
 - F) ALL TURFGRASS SEED SHALL BE LABELED TO SHOW THAT IT IS WITHIN THE REQUIREMENTS OF THE USDA AS TO PURITY, GERMINATION, AND PRESENCE OF RESTRICTED OR PROHIBITED WEEDS.
- 4) **BED PREPARATION FOR AREAS TO BE SEEDED WITH TURFGRASS:** A ROTOVATOR, CHISEL PLOW, OR CULTIVATOR SHALL BE USED TO WORK THE SOIL TO A DEPTH OF SIX INCHES. AFTER THIS OPERATION, REMOVE AND DISPOSE OF STICKS, STONES OVER 1 INCH DIAMETER, AND RUBBISH TO A MINIMUM DEPTH OF TWO INCHES.
- 5) **LIME AND NUTRIENTS FOR TURFGRASS AREAS:** LIME SHALL BE GROUND DOLOMITIC LIMESTONE, APPLIED AT THE RATE OF 50 POUNDS PER 1000 SQUARE FEET. LIME SHALL BE WELL-MIXED INTO THE TOP THREE INCHES OF LOAM.
- 6) **FERTILIZER FOR TURFGRASS AREAS:** FERTILIZER SHALL BE A COMMERCIAL GRADE WITH A MINIMUM OF 50 PERCENT OF THE NITROGEN COMPONENT IN A CONTROLLED RELEASE FORM LABELED TO RELEASE NITROGEN FOR A MINIMUM OF SIX WEEKS. FERTILIZER SHALL HAVE AN N/P/K RATIO IN THE RANGE OF 1:1:1 TO 1:2:2. IT SHALL BE APPLIED AT A RATE WHICH ACHIEVES ONE POUND OF NITROGEN PER 1000 SQUARE FEET.
- 7) **SEEDING PROCEDURE FOR TURFGRASS:** SOWING OF SEED SHALL BE DONE ONLY AFTER THE PREPARED SOIL, TO WHICH LIME AND FERTILIZER HAVE BEEN ADDED AS SPECIFIED, HAS BEEN THOROUGHLY SETTLED BY RAINFALL OR ARTIFICIAL WATERING. IMMEDIATELY BEFORE ANY SEED IS SOWN, THE GROUND SHALL BE SCARIFIED AS SPECIFIED. LAWN AREAS SHALL BE SEEDED EVENLY WITH A MECHANICAL SPREADER. SEED MIXTURES SHALL BE SOWN AT A RATE OF 5 POUNDS PER 1000 SQUARE FEET. AFTER SEEDING, THE LAWN SHALL BE LIGHTLY RAKED, ROLLED WITH A 200-POUND ROLLER, AND WATERED WITH A FINE SPRAY. THIS METHOD OF SEEDING MAY BE VARIED AT THE DISCRETION OF THE CONTRACTOR ON HIS OWN RESPONSIBILITY TO ESTABLISH A SMOOTH, UNIFORMLY GRASSED LAWN.
- 8) SEED FOR PERMANENT TURFGRASS SHALL ONLY BE SOWN FROM THE THIRD WEEK IN APRIL THROUGH JUNE AND DURING THE MONTH OF SEPTEMBER.
- 9) **TEMPORARY SEEDING FOR EROSION CONTROL:** IN THE EVENT THAT THE CONTRACT IS SUSPENDED, TEMPORARY SEEDING SHALL BE USED ON ANY BARE AREAS THAT MAY BE SUBJECT TO EROSION AND WHERE TEMPORARY VEGETATION CAN BE USED TO RETARD EROSION FROM 2 TO 12 MONTHS. THE SEED TYPE USED FOR TEMPORARY COVER SHALL BE 100 PERCENT TALL FESCUE APPLIED AT A RATE OF 300 POUNDS PER ACRE.
- 10) **MAINTENANCE:** MAINTAIN THE TURFGRASS FROM TIME OF INSTALLATION UNTIL THE FINAL INSPECTION IMMEDIATELY PRIOR TO THE BEGINNING OF THE GUARANTEE PERIOD. MAINTENANCE SHALL INCLUDE WATERING OF TURF AREAS, REPAIRS TO TURF AREAS, AND OTHER NECESSARY OPERATIONS. THE MAINTAINED TURF AREAS SHALL BE MOWED TO A UNIFORM HEIGHT OF APPROXIMATELY TWO AND ONE-HALF INCHES. MOWING SHALL BE PROVIDED AS REQUIRED SO THAT THE TURF NEVER EXCEEDS FOUR INCHES IN HEIGHT. TURF SHALL BE PROTECTED AND REPLANTED AS NECESSARY TO ESTABLISH A UNIFORM STAND OF THE SPECIFIED TURF AND UNTIL ACCEPTANCE. SCATTERED BARE SPOTS, NONE OF WHICH IS LARGER THAN ONE SQUARE FOOT, WILL BE ALLOWED UP TO A MAXIMUM OF THREE PERCENT OF ANY TURF AREA. WHEN TURF AREAS ARE READY FOR FINAL INSPECTION, THE MAINTAINED TURF AREAS SHALL BE NEATLY MOWED TO THE UNIFORM HEIGHTS AS NOTED ABOVE. THE LAWNS SHALL BE CONSIDERED ESTABLISHED ONLY WHEN THE SPECIFIED GRASS IS VIGOROUS AND GROWING WELL IN ADDITION TO MEETING THE OTHER REQUIREMENTS SPECIFIED. AT THE TIME OF ACCEPTANCE FOLLOWING FINAL INSPECTION, THE CONTRACTOR IS RELIEVED OF ROUTINE MAINTENANCE RESPONSIBILITIES FOR THE TURF UNDER THIS CONTRACT.
- 11) **FINAL INSPECTION, CLEANUP AND COMPLETION:** FINAL INSPECTION SHALL BE FOR THE COMPLETED LANDSCAPE AND SHALL BE MADE AT THE CONCLUSION OF THE LANDSCAPE WORK. UPON COMPLETION OF THE WORK, THE CONTRACTOR SHALL REMOVE FROM THE SITE ALL EQUIPMENT AND OTHER ARTICLES USED. ALL EXCESS SOIL, STONES, AND DEBRIS SHALL BE REMOVED FROM THE SITE. ALL WORK AREAS SHALL BE LEFT IN A CLEAN AND NEAT CONDITION. ALL DAMAGE TO EXISTING CONSTRUCTION CAUSED BY THE LANDSCAPING OPERATIONS SHALL BE REPAIRED TO THE SATISFACTION OF THE OWNER AT THE CONTRACTOR'S EXPENSE.
- 12) **GUARANTY AND REPLACEMENT:** IF A SATISFACTORY STAND OF MAINTAINED TURF HAS BEEN PRODUCED AT THE TIME OF FINAL INSPECTION, IT SHALL BE GUARANTEED THROUGH ONE COMPLETE GROWING SEASON. IF RENOVATION AND/OR RESEEDING ARE REQUIRED AT THE END OF THE GUARANTEE PERIOD, THIS WORK SHALL BE DONE IN CONFORMANCE WITH THE REQUIREMENTS NOTED ABOVE. IF A SATISFACTORY STAND OF MAINTAINED TURF HAS NOT BEEN PRODUCED AT THE TIME OF FINAL INSPECTION, NECESSARY REPAIRS SHALL BE PERFORMED IN CONFORMANCE WITH THE REQUIREMENTS NOTED ABOVE. UPON COMPLETION OF THESE REPAIRS, THE TURF GRASS SHALL BE GUARANTEED AS NOTED ABOVE.



PROJECT:
274 FRANKLIN ST.
WORCESTER, MA

CLIENT:
GOVENTURE
CAPITAL GROUP

DATE: 9-25-23

REVISIONS:

NO.	DATE	DESCRIPTION

SCALE: NONE

LANDSCAPE
NOTES

SHEET L-10 OF 10

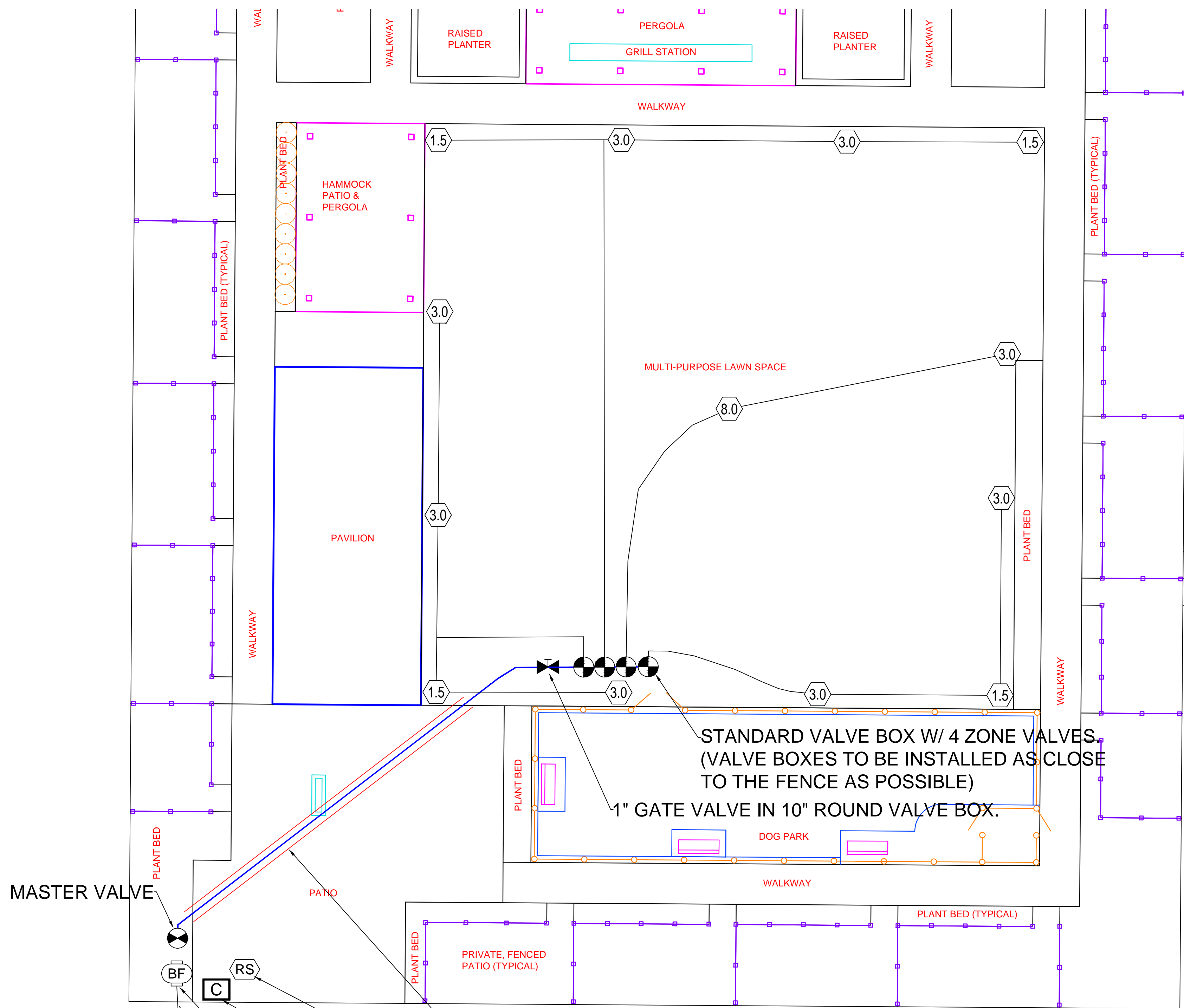

IRRIGATION SCHEDULE

SYMBOL	MANUFACTURER/MODEL	QTY
⊕1.5	Hunter I-20-04 1.5 (all heads on flexible swing joints)	4
⊕3.0	Hunter I-20-04 3.0	8
⊕8.0	Hunter I-20-04 8.0	1
SYMBOL	MANUFACTURER/MODEL	QTY
⊕	Master Valve: Hunter ICV101G 1"	1
⊕	Zone Valve: Hunter PGV-101G 1"	4
⊕	Isolation Valve: Line Sized	1
⊕BF	Backflow: Febco 850 1" Double Check on 1" Copper Pipe	1
⊕C	Controller: Hunter P2C400 w/ PCM300 Module	1
⊕RS	Rain Sensor: Hunter Rainklik, wired	1
⊕	Point of Connection: 1" @ 60 psi	1
—	Laterals: 100 psi 1" Poly Pipe	500'
—	Mainline: Class 200 1" Sw Pvc Pipe w/ #18 Uf Wire	Main: 100' Wire: 250'
—	Pipe Sleeve: Schedule 40 4" Pvc Pipe	60'

IRRIGATION NOTES

1. ALL WORK IS TO BE IN COMPLIANCE WITH ALL LOCAL, STATE AND FEDERAL CODES AND ORDINANCES.
2. ALL REMOTE CONTROL VALVES ARE TO BE INSTALLED IN VALVE BOXES AS NEEDED.
3. ALL CONTROL WIRING DOWNSTREAM OF THE CONTROLLER IS TO BE #18/9 UF WIRE. USE DBY-6 CONNECTORS WHERE NEEDED.
4. FOLLOW ALL MANUFACTURER'S INSTALLATION INSTRUCTIONS.
5. SYSTEM IS DESIGNED FOR UP TO 12 GPM PER ZONE. PRESSURE AT THE INLET TO THE BACKFLOW SHALL BE 65 PSI.
6. ANY CHANGES IN AVAILABILITY OF SUPPLY SHOULD BE NOTED AND MODIFICATIONS TO THE DESIGN SHOULD BE MADE.
7. CONTRACTOR TO VERIFY WATER PRESSURE AND AVAILABILITY PRIOR TO INSTALLATION.
8. THE LOCATION OF ALL IRRIGATION IS DIAGRAMMATIC AND SUBJECT TO FIELD VERIFICATION. IRRIGATION PIPING SHOWN OUTSIDE OF CURBS FOR CLARITY ONLY.
9. WATER: 1" @ 60 PSI, BY OTHERS.
10. BACKFLOW: 1" DOUBLE CHECK, BY OTHERS.
11. POWER: 115 VAC DEDICATED OUTLET, BY OTHERS.

MASTER VALVE

BF

RS

C

4" PVC SLEEVE W/ 1" PVC MAIN & #18 UF WIRE

FIELD LOCATE WIRED RAIN SENSOR

CONTROLLER: OUTDOOR WALL MOUNT, HIDDEN IN LANDSCAPE, REQUIRES DEDICATED 115 VAC OUTLET. WIRES & CONNECTORS AS NEEDED.

BACKFLOW: 1" DOUBLE CHECK ON 1" COPPER PIPE. INSTALL 3/4" HOSE BIB BEFORE D.C. FOR BLOW OUT.

STUB OUT: 1" TYPE K COPPER PIPE W/ MPT END

POC: 1" WATER TAP @ 60 PSI. INSTALL 1" GATE VALVE. INSTALL DRAIN ON STUB OUT.

STANDARD VALVE BOX W/ 4 ZONE VALVES. (VALVE BOXES TO BE INSTALLED AS CLOSE TO THE FENCE AS POSSIBLE)
1" GATE VALVE IN 10" ROUND VALVE BOX.

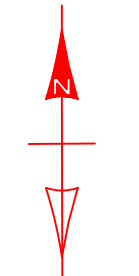
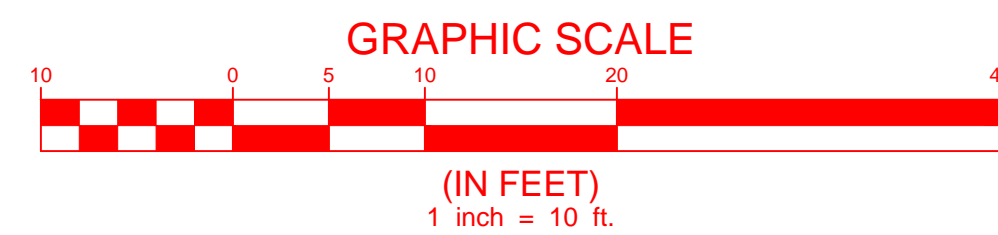

<p>274 Franklin Street Courtyard Worcester, MA</p> <p>SECTION 328400 - PLANTING IRRIGATION</p> <p>PART 1 - GENERAL</p> <p>1.1 RELATED DOCUMENTS</p> <p>A. Drawings and general provisions of the Contract, including General and Supplementary Conditions and Division 01 Specification Sections, apply to this Section.</p> <p>1.2 SUMMARY</p> <p>A. Section Includes:</p> <ol style="list-style-type: none"> Piping. Sleeving for piping. Manual valves. Automatic control valves. Miscellaneous piping specialties. Sprinklers. Controllers. Boxes for automatic control valves. Wiring and connections. <p>1.3 DEFINITIONS</p> <p>A. Circuit Piping: Downstream from control valves to sprinklers, specialties, and drain valves. Piping is under pressure during flow.</p> <p>B. Drain Piping: Downstream from circuit-piping drain valves. Piping is not under pressure.</p> <p>C. Main Piping: Downstream from point of connection to water distribution piping to, and including, control valves. Piping is under water-distribution-system pressure.</p> <p>D. Low Voltage: As defined in NFPA 70 for circuits and equipment operating at less than 50 V or for remote-control, signaling power-limited circuits.</p> <p>1.4 PERFORMANCE REQUIREMENTS</p> <p>A. Irrigation zone control shall be automatic operation with controller and automatic control valves.</p> <p>B. Location of Sprinklers and Specialties: Design location is approximate. Make minor adjustments necessary to avoid plantings and obstructions such as signs and light standards. Maintain 100 percent irrigation coverage of areas indicated.</p> <p>PLANTING IRRIGATION 328400 - 1</p>	<p>274 Franklin Street Courtyard Worcester, MA</p> <p>C. Delegated Design: Design 100 percent coverage irrigation system, including comprehensive engineering analysis by a qualified professional engineer, using performance requirements and design criteria indicated.</p> <p>D. Water supply from a 1" domestic supply, by others. Power supply by others. Sleeving & conduit by others.</p> <p>1.5 SUBMITTALS</p> <p>A. Product Data: For each type of product indicated. Include rated capacities, operating characteristics, and furnished specialties and accessories.</p> <p>B. Delegated-Design Submittal: For irrigation systems indicated to comply with performance requirements and design criteria, including analysis data signed and sealed by the qualified professional engineer responsible for their preparation.</p> <p>C. Coordination Drawings: Irrigation systems, drawn to scale, on which components are shown and coordinated with each other, using input from installers of the items involved. Also include adjustments necessary to avoid plantings and obstructions such as signs and light standards.</p> <p>D. Qualification Data: Installer shall provide proof of the installation of three projects of a similar nature. Provide a written report with the bid stating project name, location, contact name, and an email or phone number for the contact.</p> <p>E. Field quality-control reports.</p> <p>F. Operation and Maintenance Data: Include operation and maintenance manuals.</p> <p>1.6 QUALITY ASSURANCE</p> <p>A. Installer Qualifications: Provide proof of (3) projects of a similar nature. Provide a report with date of installation, project name, project location, contact name, contact email address and phone number. Submit report with the bid.</p> <p>B. Electrical Components, Devices, and Accessories: Listed and labeled as defined in NFPA 70, by a qualified testing agency, and marked for intended location and application.</p> <p>1.7 DELIVERY, STORAGE, AND HANDLING</p> <p>A. Deliver piping with factory-applied end caps. Maintain end caps through shipping, storage, and handling to prevent pipe-end damage and to prevent entrance of dirt, debris, and moisture.</p> <p>B. Store plastic piping protected from direct sunlight. Support to prevent sagging and bending.</p> <p>PLANTING IRRIGATION 328400 - 2</p>	<p>274 Franklin Street Courtyard Worcester, MA</p> <p>1.8 PROJECT CONDITIONS</p> <p>A. Interruption of Existing Water Service: Do not interrupt water service to facilities occupied by Owner or others unless permitted under the following conditions and then only after arranging to provide temporary water service according to requirements indicated:</p> <ol style="list-style-type: none"> Notify Construction Manager no fewer than two days in advance of proposed interruption of water service. Do not proceed with interruption of water service without Construction Manager's written permission. <p>1.9 EXTRA MATERIALS</p> <p>A. Furnish extra materials that match products installed and that are packaged with protective covering for storage and identified with labels describing contents.</p> <ol style="list-style-type: none"> Sprinklers: 2 extra of each. Automatic Control Valves: 1 extra of each Keys to controller cabinet: 2 <p>PART 2 - PRODUCTS</p> <p>2.1 PIPES, TUBES, AND FITTINGS</p> <p>A. Comply with requirements in the piping schedule for applications of pipe, tube, and fitting materials, and for joining methods for specific services, service locations, and pipe sizes.</p> <p>B. Soft Copper Tube: ASTM B 88, Type L (ASTM B 88M, Type B), water tube, annealed temper.</p> <p>C. Copper Pressure Fittings: ASME B16.18, cast-copper-alloy or ASME B16.22, wrought-copper solder-joint fittings. Furnish wrought-copper fittings if indicated.</p> <p>D. Bronze Flanges: ASME B16.24, Class 150, with solder-joint end.</p> <p>E. Copper Unions: MSS SP-123, cast-copper-alloy, hexagonal-stock body, with ball-and-socket, metal-to-metal seating surfaces and solder-joint or threaded ends.</p> <p>F. PVC Pipe: ASTM D 1785, PVC 1120 compounding, SDR 21, Class 200.</p> <p>G. PVC Socket Fittings: ASTM D 2466, Schedule 40.</p> <p>H. PVC Threaded Fittings: ASTM D 2464, Schedule 80.</p> <p>I. Poly Pipe: ASTM D2239, 160 PSI.</p> <p>J. Insert Fittings & Saddles</p> <p>2.2 PIPING JOINING MATERIALS</p> <p>A. Metal, Pipe-Flange Bolts and Nuts: ASME B18.2.1, carbon steel unless otherwise indicated.</p> <p>PLANTING IRRIGATION 328400 - 3</p>	<p>274 Franklin Street Courtyard Worcester, MA</p> <p>B. Brazing Filler Metals: AWS A5.8/A5.8M, BCoP Series, copper-phosphorus alloys for general-duty brazing unless otherwise indicated.</p> <p>C. Solder Filler Metals: ASTM B 32, lead-free alloys. Include water-flushable flux according to ASTM B 813.</p> <p>D. Solvent Cements for Joining PVC Piping: ASTM D 2564. Include primer according to ASTM F 656.</p> <p>E. Ear clamps for insert fittings for Poly Pipe</p> <p>2.3 SLEEVING FOR PIPING</p> <p>A. Standard: ASTM D 1785, Schedule 40 PVC.</p> <p>2.4 MANUAL VALVES</p> <p>A. Brass Valves:</p> <ol style="list-style-type: none"> Manufacturers: Subject to compliance with requirements. Basic-of-Design Product: Subject to compliance with requirements, provide or comparable product by one of the following: <ol style="list-style-type: none"> Mato <p>2.5 AUTOMATIC CONTROL VALVES</p> <p>A. Plastic, Automatic Control Valves:</p> <ol style="list-style-type: none"> Manufacturers: Subject to compliance with requirements. Basic-of-Design Product: Subject to compliance with requirements, provide or comparable product by one of the following: <ol style="list-style-type: none"> Hunter PGT for zone and ICV for master valves. Description: Molded-plastic body, normally closed, diaphragm type with manual-flow adjustment, and operated by 24-V ac solenoid. <p>2.6 MISCELLANEOUS PIPING SPECIALTIES</p> <p>A. Water Hammer Arresters: ASSE 1016 or PDI WH 201, with bellows or piston-type pressurized cushioning chamber and in sizes complying with PDI WH 201, Sizes A to F.</p> <p>B. Pressure Gages: ASME B40.1. Include 4-1/2-inch (115-mm) diameter dial, dial range of two times system operating pressure, and bottom outlet.</p> <p>C. Pressure reducer, if required.</p> <p>PLANTING IRRIGATION 328400 - 4</p>	<p>274 Franklin Street Courtyard Worcester, MA</p> <p>2.7 SPRINKLERS</p> <p>A. General Requirements: Designed for uniform coverage over entire spray area indicated at available water pressure.</p> <p>B. Medium Rotary Sprinklers:</p> <ol style="list-style-type: none"> Manufacturers: Subject to compliance with requirements. Basic-of-Design Product: Subject to compliance with requirements, provide or comparable product by one of the following: <ol style="list-style-type: none"> Hunter Industries - D204 Description: <ol style="list-style-type: none"> Body Material: AHS. Nozzle: Plastic. Retraction Spring: Stainless steel. Internal Parts: Corrosion resistant. Flow: 1.12 to 9.8 GPM Pop-up Height: 4" aboveground to nozzle. Arc: 0 to 360 degrees. Radius: 29" to 46" Inlet: 3/4" IPS <p>2.8 CONTROLLERS</p> <p>A. Manufacturers: Subject to compliance with requirements.</p> <p>B. Basic-of-Design Product: Subject to compliance with requirements, or comparable product by one of the following:</p> <ol style="list-style-type: none"> Hunter Industries Incorporated - P2C with module. <p>C. Description:</p> <ol style="list-style-type: none"> Controller Stations for Automatic Control Valves: Include switch for manual or automatic operation of each station. Interior Control Enclosures: NEMA 250, Type 4, weatherproof, with locking cover and two matching keys; include provision for grounding. <ol style="list-style-type: none"> Body Material: Molded plastic. Mounting: Surface type for wall. Control Transformer: 24-V secondary, with primary fuse. Timing Device: Adjustable, 24-hour, 14-day clock, with automatic operations to skip operation any day in timer period, to operate every other day, or to operate two or more times daily. <p>PLANTING IRRIGATION 328400 - 5</p>	<p>274 Franklin Street Courtyard Worcester, MA</p> <p>a. Manual or Semi-automatic Operation: Allows this mode without disturbing preset automatic operation.</p> <p>b. Nickel-Cadmium Battery and Trickle Charger: Automatically powers timing device during power outages.</p> <p>c. Surge Protection: Metal-oxide-varistor type on each station and primary power.</p> <p>5. Rain sensor, wired to interrupt the cycle during a rain fall.</p> <p>6. Wiring: UL 493, Type UF #18 gauge multi strand wire, with solid-copper conductors; insulated cable, suitable for direct burial.</p> <p>a. Splicing Materials: Manufacturer's packaged kit consisting of insulating, spring-type connector or crimped joint and epoxy resin moisture seal; suitable for direct burial.</p> <p>2.9 BOXES FOR AUTOMATIC CONTROL VALVES</p> <p>A. Plastic Boxes:</p> <ol style="list-style-type: none"> Manufacturers: Subject to compliance with requirements. <ol style="list-style-type: none"> Armorcast Products Company. Cirson Industries LLC. NDS Pro Description: Box and cover, with open bottom and openings for piping; designed for installing flush with grade. <ol style="list-style-type: none"> Size: As required for valves and services. Shape: [Round] [Square] [Rectangular]. SideWall Material: PE. Cover Material: PE. <p>1) Lettering: "[VALVE BOX] [IRRIGATION]"</p> <p>2.10 BACKFLOW</p> <ol style="list-style-type: none"> Manufacturers: Subject to compliance with requirements. <ol style="list-style-type: none"> Watts F630 Description: Backflow shall be a reduced pressure type. <p>PLANTING IRRIGATION 328400 - 6</p>
--	---	--	---	---	---

<p>274 Franklin Street Courtyard Worcester, MA</p> <p>PART 3 - EXECUTION</p> <p>3.1 EARTHWORK</p> <p>A. Excavating, trenching, and backfilling are specified in Division 31 Section "Earth Moving."</p> <p>B. Install warning tape directly above pressure piping, 12 inches below finished grades, except 6 inches below subgrade under pavement and slabs.</p> <p>C. Provide minimum cover over top of underground piping according to the following:</p> <ol style="list-style-type: none"> Irrigation Main Piping: Minimum depth of 18 inches below finished grade Circuit Piping: 12 inches Sleeves: 12 inches <p>3.2 PREPARATION</p> <p>A. Set stakes to identify locations of proposed irrigation system. Obtain Architect's approval before excavation.</p> <p>3.3 PIPING INSTALLATION</p> <p>A. Location and Arrangement: Drawings indicate location and arrangement of piping systems. Install piping as indicated unless deviations are approved on Coordination Drawings.</p> <p>B. Install piping at minimum uniform slope of 0.5 percent down toward drain valves.</p> <p>C. Install piping free of sags and bends.</p> <p>D. Install groups of pipes parallel to each other, spaced to permit valve servicing.</p> <p>E. Install fittings for changes in direction and branch connections.</p> <p>F. Install underground thermoplastic piping according to ASTM D 2774 and ASTM F 690.</p> <p>G. Install expansion loops in control-valve boxes for plastic piping.</p> <p>H. Lay piping on solid subbase, uniformly sloped without humps or depressions.</p> <p>I. Install PVC piping in dry weather when temperature is above 40 deg F (5 deg C). Allow joints to cure at least 24 hours at temperatures above 40 deg F (5 deg C) before testing.</p> <p>J. Install piping in sleeves under parking lots, roadways, and sidewalks.</p> <p>K. Install sleeves made of Class 200 PVC pipe and socket fittings, and solvent-cemented joints.</p> <p>L. Install transition fittings for plastic-to-metal pipe connections according to the following:</p> <ol style="list-style-type: none"> Underground Piping: <p>PLANTING IRRIGATION 328400 - 7</p>	<p>274 Franklin Street Courtyard Worcester, MA</p> <p>a. NPS 1-1/2 (DN 40) and Smaller: Plastic-to-metal transition fittings.</p> <p>b. NPS 2 (DN 50) and Larger: AWWA transition couplings.</p> <p>2. Aboveground Piping:</p> <p>a. NPS 2 (DN 50) and Smaller: Plastic-to-metal transition [fittings] [unions].</p> <p>b. NPS 3 (DN 50) and Larger: Use dielectric flange kits with one plastic flange.</p> <p>3.4 JOINT CONSTRUCTION</p> <p>A. Ream ends of pipes and tubes and remove burrs. Bevel plain ends of steel pipe.</p> <p>B. Remove scale, slag, dirt, and debris from inside and outside of pipe and fittings before assembly.</p> <p>C. Threaded Joints: Thread pipe with tapered pipe threads according to ASME B1.20.1. Cut threads full and clean using sharp dies. Ream threaded pipe ends to remove burrs and restore full ID. Join pipe fittings and valves as follows:</p> <ol style="list-style-type: none"> Apply appropriate tape or thread compound to external pipe threads unless dry seal threading is specified. Damaged Threads: Do not use pipe or pipe fittings with threads that are corroded or damaged. Do not use pipe sections that have cracked or open welds. <p>D. Copper-Tubing Heated Joints: Construct joints according to CDA's "Copper Tube Handbook," using copper-phosphorus brazing filler metal.</p> <p>E. Copper-Tubing Soldered Joints: Apply ASTM B 813 water-flushable flux to tube end unless otherwise indicated. Construct joints according to ASTM B 828 or CDA's "Copper Tube Handbook," using lead-free solder alloy (0.20 percent maximum lead content) complying with ASTM B 32.</p> <p>F. PVC Piping Solvent-Cemented Joints: Clean and dry joining surfaces. Join pipe and fittings according to the following:</p> <ol style="list-style-type: none"> Comply with ASTM F 402 for safe-handling practice of cleaners, primers, and solvent cements. PVC Pressure Piping: Join schedule number, ASTM D 1785, PVC pipe and PVC socket fittings according to ASTM D 2672. Join other-duty-schedule-number PVC pipe and socket fittings according to ASTM D 2855. PVC Nonpressure Piping: Join according to ASTM D 2855. <p>3.5 VALVE INSTALLATION</p> <p>A. Install in underground piping in boxes for automatic control valves. Install DBY splice kits at each automatic control valve. Fittings and nipples as required.</p> <p>PLANTING IRRIGATION 328400 - 8</p>	<p>274 Franklin Street Courtyard Worcester, MA</p> <p>3.6 SPRINKLER INSTALLATION</p> <p>A. Install sprinklers after hydrostatic test is completed.</p> <p>B. Install sprinklers at manufacturer's recommended heights. Install on flexible swing joints.</p> <p>C. Locate part-circle sprinklers to maintain a minimum distance of 4 inches (100 mm) from walls and 2 inches (50 mm) from other boundaries unless otherwise indicated.</p> <p>3.7 AUTOMATIC IRRIGATION-CONTROL SYSTEM INSTALLATION</p> <p>A. Equipment Mounting: Install outdoor controller on wall.</p> <ol style="list-style-type: none"> Place and secure anchorage devices. Use setting drawings, templates, diagrams, instructions, and directions furnished with items to be embedded. Install anchor bolts to elevations required for proper attachment to supported equipment. <p>B. Install control cable in same trench as irrigation. Provide conductors of size not smaller than recommended by controller manufacturer. Install cable in separate sleeve under paved areas. Use expansion loops, by wrapping around a 1" dowel 12" long, every 50'.</p> <p>3.8 CONNECTIONS</p> <p>A. Comply with requirements for piping specified in Division 22 Section "Facility Water Distribution Piping" for water supply from exterior water service piping, water meters, protective enclosures, and backflow preventers. Drawings indicate general arrangement of piping, fittings, and specialties.</p> <p>B. Install piping adjacent to equipment, valves, and devices to allow service and maintenance.</p> <p>C. Connect wiring between controllers and automatic control valves.</p> <p>3.9 IDENTIFICATION</p> <p>A. Identify system components. Comply with requirements for identification specified in Division 22 Section "Identification for Plumbing Piping and Equipment."</p> <p>B. Equipment Nameplates and Signs: Install engraved plastic-laminate equipment nameplates and signs on each automatic controller.</p> <ol style="list-style-type: none"> Text: In addition to identifying unit, distinguish between multiple units, inform operator of operational requirements, indicate safety and emergency precautions, and warn of hazards and improper operations. <p>3.10 FIELD QUALITY CONTROL</p> <p>A. Manufacturer's Field Service: Engage a factory-authorized service representative to inspect, test, and adjust components, assemblies, and equipment installations, including connections.</p> <p>PLANTING IRRIGATION 328400 - 9</p>	<p>274 Franklin Street Courtyard Worcester, MA</p> <p>B. Perform tests and inspections.</p> <ol style="list-style-type: none"> Manufacturer's Field Service: Engage a factory-authorized service representative to inspect components, assemblies, and equipment installations, including connections, and to assist in testing. <p>C. Tests and Inspections:</p> <ol style="list-style-type: none"> Leak Test: After installation, charge system and test for leaks. Repair leaks and retest until no leaks exist. Operational Test: After electrical circuitry has been energized, operate controllers and automatic control valves to confirm proper system operation. Test and adjust controls and safeties. Replace damaged and malfunctioning controls and equipment. <p>D. Any irrigation product will be considered defective if it does not pass tests and inspections.</p> <p>E. Prepare test and inspection reports.</p> <p>3.11 STARTUP SERVICE</p> <p>A. Startup service shall be the responsibility of the irrigation installer.</p> <ol style="list-style-type: none"> Complete installation and startup checks according to manufacturer's written instructions. Verify that controllers are installed and connected according to the Contract Documents. Verify that electrical wiring installation complies with manufacturer's submittal. <p>3.12 ADJUSTING</p> <p>A. Adjust settings of controllers.</p> <p>B. Adjust automatic control valves to provide flow rate at rated operating pressure required for each sprinkler circuit.</p> <p>C. Adjust sprinklers and devices, except those intended to be mounted aboveground, so they will be flush with finish grade.</p> <p>3.13 CLEANING</p> <p>A. Flush dirt and debris from piping before installing sprinklers and other devices.</p> <p>3.14 DEMONSTRATION</p> <p>A. Train the Owner's maintenance personnel to adjust, operate, and maintain this system.</p> <p>PLANTING IRRIGATION 328400 - 10</p>	<p>274 Franklin Street Courtyard Worcester, MA</p> <p>3.15 PIPING SCHEDULE:</p> <p>A. Install components having pressure rating equal to or greater than system operating pressure.</p> <p>B. Piping in control-valve boxes and aboveground may be joined with flanges or unions instead of joints indicated.</p> <p>C. Underground irrigation main piping:</p> <ol style="list-style-type: none"> SDR 21, PVC, pressure-rated pipe; Schedule 80, PVC socket fittings; and solvent-cemented joints. <p>D. Underground Circuit piping.</p> <ol style="list-style-type: none"> POLY pipe and insert & saddle fittings. <p>END OF SECTION 328400</p> <p>PLANTING IRRIGATION 328400 - 11</p>
---	---	---	--	---



1-800-347-4272
http://www.projects-services.siteone.com

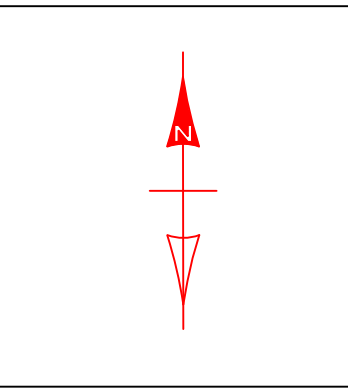

274 FRANKLIN STREET - COURTYARD
WORCESTER, MASSACHUSETTS

IRRIGATION SPECIFICATIONS
Sheet Number: IR-2
Designed By: eaban
Date: 9/22/2023
Drawing Scale: 1" = 10'-0"
Project Number: